



Medium Pressure Products

MPI™ Fittings and Valves
6,000 – 15,000 PSI Range

Catalog 4234

August 2010

aerospace
climate control
electromechanical
filtration
fluid & gas handling
hydraulics
pneumatics
process control
sealing & shielding



ENGINEERING YOUR SUCCESS.

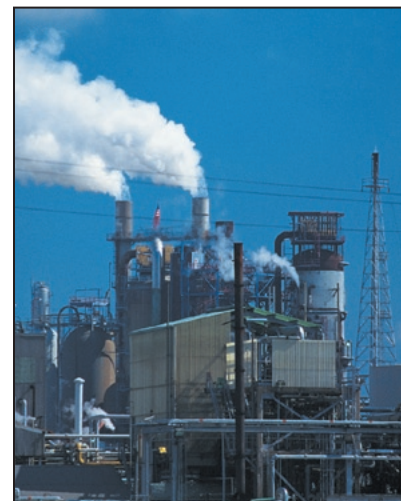

Introduction

Parker Hannifin MPI™ Fittings are engineered and manufactured to provide secure, tight, and leak-resistant connections throughout industry, including off-shore oil and gas exploration platforms, research labs, and other facilities that require operating pressures in the range of 6,000 to 15,000 psi.

MPI™ Fittings are ideally suited to handle liquids, gases, or chemicals and can be used on a wide variety of tubing materials including cold drawn – 1/8 hard (unannealed) tubing or instrument grade thick-walled annealed stainless steel. Every Parker MPI™ Fitting is supplied complete and ready to install.

Advanced Features

Every MPI™ Fitting has the features shown below:

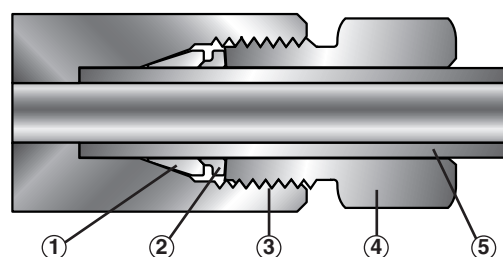

1. Front ferrule with corrosion-resistant Parker Supercase® forms a tight pressure seal between the body and ferrule in a second strong mechanical hold on the tube.
2. Rear ferrule with corrosion-resistant Parker Supercase® provides a strong mechanical hold on the tube.
3. Longer thread area for improved resistance to pressure and load on the ferrules.
4. Molybdenum disulfide-coated inverted nut helps prevent galling, provides easier assembly, and permits multiple remakes.
5. Long tube-support area improves resistance to vibration and line loads.

WARNING – USER RESPONSIBILITY

FAILURE OR IMPROPER SELECTION OR IMPROPER USE OF THE PRODUCTS DESCRIBED HEREIN OR RELATED ITEMS CAN CAUSE DEATH, PERSONAL INJURY AND PROPERTY DAMAGE.

This document and other information from Parker-Hannifin Corporation, its subsidiaries and authorized distributors provide product or system options for further investigation by users having technical expertise.

The user, through its own analysis and testing, is solely responsible for making the final selection of the system and components and assuring that all performance, endurance, maintenance, safety and warning requirements of the application are met. The user must analyze all aspects of the application, follow applicable industry standards, and follow the information concerning the product in the current product catalog and in any other materials provided from Parker or its subsidiaries or authorized distributors.

To the extent that Parker or its subsidiaries or authorized distributors provide component or system options based upon data or specifications provided by the user, the user is responsible for determining that such data and specifications are suitable and sufficient for all applications and reasonably foreseeable uses of the components or systems.

Offer of Sale

The items described in this document are hereby offered for sale by Parker-Hannifin Corporation, its subsidiaries or its authorized distributors. This offer and its acceptance are governed by the provisions stated in the detailed "Offer of Sale" elsewhere in this document or available at www.parker.com/ipdus.

Materials and Identification

Standard MPI™ Fittings are made of Heat Code Traceable 316 stainless steel. Tubing and fitting materials should be selected based on compatibility with the fluid or gas media.

Part numbers for MPI™ Fittings use symbols that identify their style, size, and composition.

MPI™ Fittings Pressure Ratings

The maximum pressure rating is marked on each fitting. MPI™ working pressures to be determined by selecting tubing. Please see tables on [page 3](#) for specific working pressures.

- Size 4 MPI™ end – to 15,000 psi
- Size 6 MPI™ end – to 15,000 psi
- Size 8 MPI™ end – to 15,000 psi
- Size 9 MPI™ end – to 15,000 psi
- Size 12 MPI™ end – to 15,000 psi
- Size 16 MPI™ end – to 12,500 psi

Assembly

MPI™ Fittings are installed with standard hand tools. Each size can be preset with a Parker hydraulic preset tool. Tube preparation does not require cutting of threads or tube end “coning.”

Dedication to Quality

Our resources and vast product line, is available through our worldwide distribution network.

For more information regarding our products and services, please contact your authorized Parker Instrumentation Distributor.









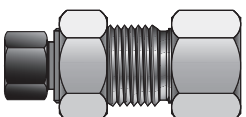

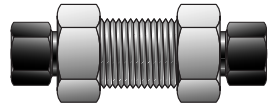
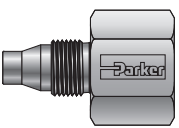
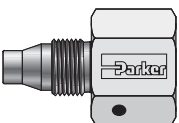



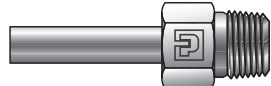
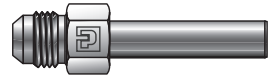

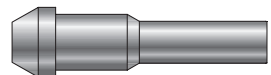

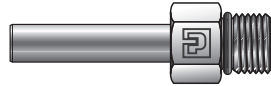
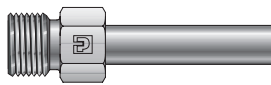

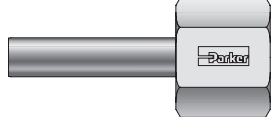

Table of Contents

Introduction	ii
Visual Index	iv
MPI™ Fittings	
Typical Raw Materials	1
Tube End Dimension Data	1
How To Order	1
Tubing Selection Guide	2
Temperature Derating Factors	2
Maximum Allowable Working Pressure Tables	3
Medium Pressure Fittings	5
Gaugeability Tools	23
Medium Pressure Valves	
MPN Series Valves	24
Over Critical Valves	30
Bleed Valve	31
Gauge Valve	31
MPB Series Valves	32
MPF Series Filters	36
MPC and MPCB Series Check Valves	37
MPR Series Relief Valves	38
HB4 Series Ball Valves	39
Double Block and Bleed Valves	40
15,000 PSI, Ultra High Flow Ball Valves	42
Technical Information	
Assembly Instructions	44
Gaugeability Instructions	44
Remake Instructions	44
Hydraulic Preset Tools	45
Offer of Sale	47





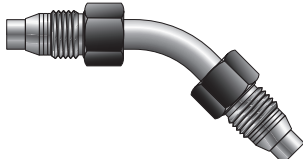
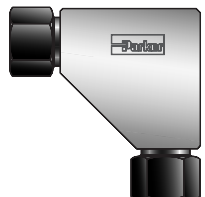

Visual Index



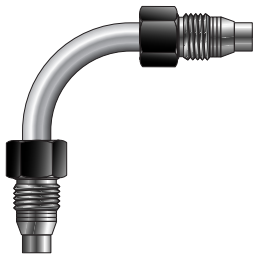
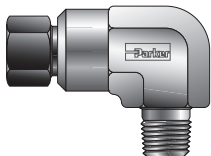

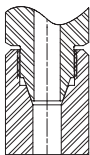
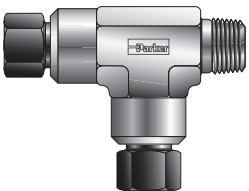
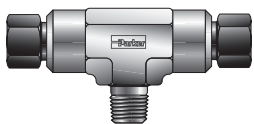

MPI™ Fittings

	FBMP7 MPI™ Male Connector Page 5
	XHBM7 37° Flare to MPI™ Connector Page 5
	MP7H2BX 37° Flare Bulkhead to MPI™ Connector Page 6
	X41HBMP7 High Pressure to MPI™ Connector Page 6
	X42HBMP7 Medium Pressure to MPI™ Connector Page 7
	GBMP7 MPI™ to Female NPT Connector Page 7
	MP7HBA MPI™ to SAE Male O-ring Connector Page 8
	M40HBMP7 Type "M" High Pressure Hose to MPI™ Connector Page 8
	GH2BMP7 MPI™ Bulkhead to Female NPT Page 9
	HBMP7 MPI™ Union Connector Page 9
	WBMP7 MPI™ Bulkhead Union Connector Page 10
	GM7 MPI™ Male End to Female NPT Page 10
	GM7 MPI™ Male End to High Pressure C&T Port Page 10

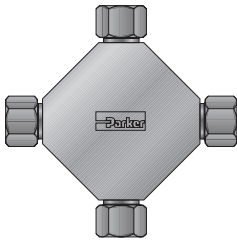
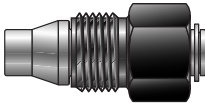
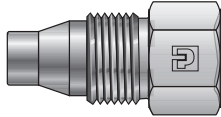
	T7HBT7 MPI™ Tube Port Connector Page 11
	T7HF MPI™ Tube Stub to Male NPT Pipe Page 11
	XHT7 37° Flare to MPI™ Tube Stub Page 12
	X41HT7 High Pressure to MPI™ Tube Stub Page 12
	X47HT7 Medium Pressure Port Connector to MPI™ Tube Stub Page 12
	X42HT7 Medium Pressure to MPI™ Tube Stub Page 13
	T7HOA MPI™ Tube Stub to Male SAE O-ring Page 13
	M40HT7 Type "M" High Pressure Hose Adapter to MPI™ Tube Stub Page 13
	TRBMP7 MPI™ Tube Stub Reducer Page 14
	T7HG MPI™ Tube Stub to Female NPT Pipe Page 14
	MP7PC MPI™ Port Connector Page 15
	NBMP7 45° MPI™ Union Elbow Page 15
	T7NBT7 45° MPI™ Tube Stub Elbow Page 16
	EBMP7 MPI™ Union Elbow Page 16

Visual Index (Continued)

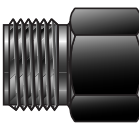
	T7EBT7 MPI™ Tube Elbow Page 17
	CBMP7 MPI™ to Male NPT Elbow ... Page 17
	JBMP7 MPI™ Union Tee Page 18
	X44HBMP7 X44 Male by MPI™ Connector Page 19
	X44HT7 X44 Male by MPI™ Tube Stub Page 19
	M40HX44 Type "M" Male by X44 Male Page 19
	X44 Adapter Assembly Page 19
	RBMP7 MPI™ to NPT Male Run Tee Page 20
	SBMP7 MPI™ to NPT Male Branch Tee Page 20
	OBMP7 MPI™ to NPT Female Branch Tee Page 21

	KBMP7 MPI™ Union Cross Page 21
	FNMP7 MPI™ Plug Page 22
	FNM7 MPI™ Plug Page 22
	PNBMP7 MPI™ Cap Page 22
	MPFF MPI™ Front Ferrule Page 22
	MPBF MPI™ Back Ferrule Page 23
	BMP7 MPI™ Nut Page 23
	Gap Gauge Page 23

Medium Pressure Valves

MP Valve Connection Types	Page 24
Two Way Inline Valves	Page 25

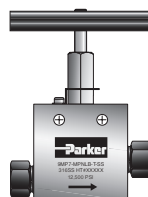

(The Visual Index is continued on the following page.)

Visual Index (Continued)

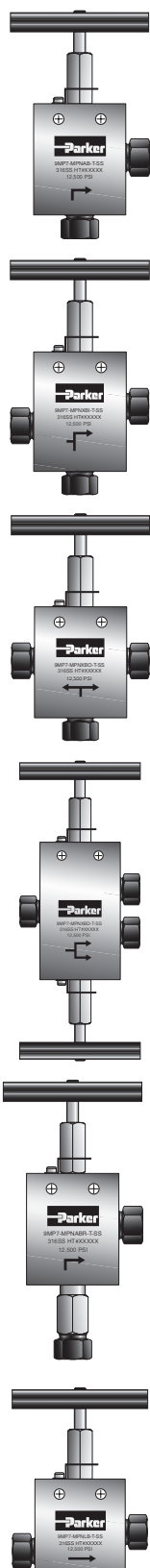

Two Way Angle Valves
..... Page 26

Three Way/Two Pressure Connections
..... Page 27

Three Way/One Pressure Connection
..... Page 27

Three Way/Two Stem Connection
..... Page 28

Two Way Angle Valves (Replaceable Seat)
..... Page 28

Over Critical Valves
..... Page 30

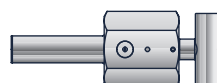

Medium Pressure Bleed Valve
..... Page 31

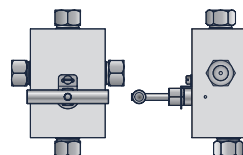

Medium Pressure Gauge Valve
..... Page 31



Two Way Ball Valves
..... Page 32

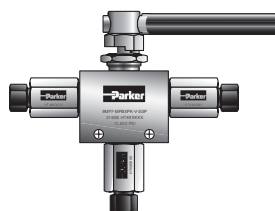

Three Way Ball Valves
..... Page 33



Inline Filters
..... Page 36



Ball Check Valves
..... Page 37



Poppet Check Valves
..... Page 37



Relief Valves (Factory Set)
..... Page 38



HB4 Series Ball Valves
..... Page 39

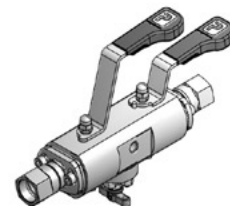

DBB Double Block and Bleed Valves
..... Page 40

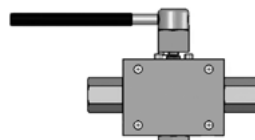

15,000 PSI, Ultra High Flow Ball Valves
..... Page 42

Technical Information

Hydraulic Present Tools Page 44

Typical Raw Material Specifications

Basic Fitting Material	Bar Stock	Forging
Stainless Steel (Type 316) (1)	ASME/ASTM SA/A-479	ASME SA-182 316
	Type 316-SS	BS970 316-S31
	AStm A-276	DIN 4401
	Type 316	
	BS970 316-S31	
	DIN 4401	

- (1) If additional information, including heat code traceability, is required, contact Parker Hannifin or your nearest MPI™ Fitting distributor.
- (2) Parker MPI™ Fittings work reliably on cold drawn - 1/8 hard tubing (both MPI™ and Cone & Thread), and fully annealed, heavy wall type 316 tubing. See [page 3](#) for more information about tubing.

Tube End Dimensional Data

Size No.	Inches						
	Tube O.D.	Straight Thread	C	D	E	*L	W Hex
4	1/4	1/2 - 20	.50	1.34	.13	1.62	9/16
6	3/8	5/8 - 20	.63	1.58	.25	1.88	11/16
8	1/2	13/16 - 20	.69	1.85	.31	2.25	15/16
9	9/16	7/8 - 20	.75	1.91	.38	2.25	1
12	3/4	1 1/8 - 18	.88	2.26	.52	2.75	1 1/4
16	1	1 7/16 - 18	1.13	2.88	.69	3.38	1 1/2

*L - Recommended Straight Length of Circular Un-bent Tubing

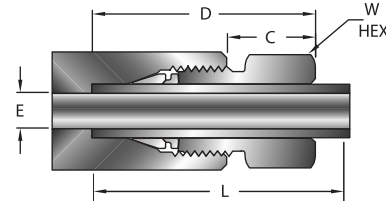

How To Order MPI™ Fittings

Parker MPI™ Fittings should be ordered using the part number as listed in this catalog.

Part numbers are developed as follows:

1. A combination of letters and numbers identifies the size and style of the fitting and the material used.
2. Tube and pipe thread sizes are designated by the number of sixteenths of an inch (1/4" tube = 4/16" or 4).

All standard MPI™ Fittings are manufactured from 316 stainless steel. Other materials are available upon special order.

Straights and Elbows: Specify the largest end of the MPI first, followed by the smaller tube end OR pipe thread size.

Example:

Part number 4-4 HBMP7 union would have the specifications listed below.

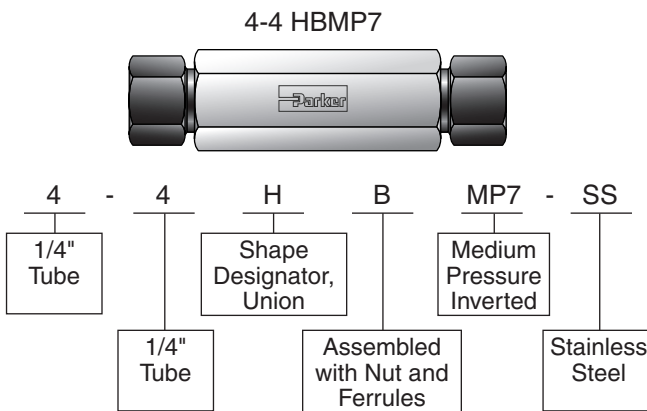

Tees:

Example:

Part number 9-6-6 JBMP7 would have the following specifications:

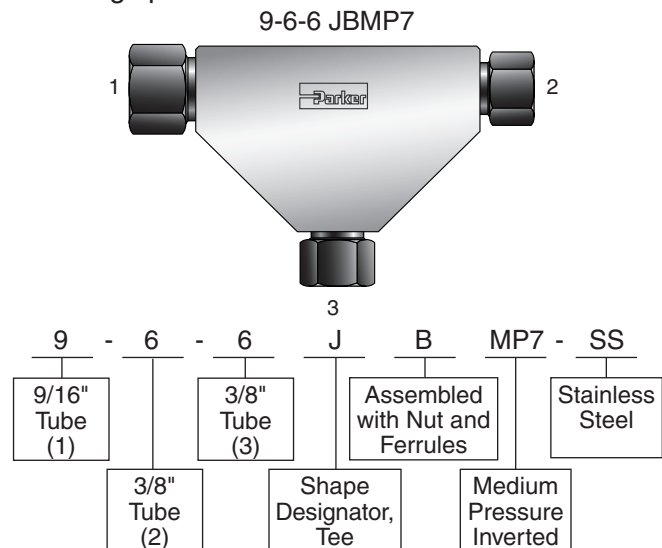

Customer Requests: When special configurations are required, please provide a blueprint of the installation to Parker with your request for a price quote.

Cryogenic Service: MPI™ fittings for cryogenic applications include a vent hole to prevent pressure build-up in front of the threads. To order "vented" MPI™ parts, add "-VT" to the end of the standard part number (e.g., 6-6 HBMP7-SS becomes 6-6 HBMP7-SS-VT).

Tubing Selection Guide

Although Parker's MPI™ Fittings are engineered and manufactured to consistently provide high levels of reliability, no system's integrity is complete without considering the critical link: tubing.

This section is intended to help you properly select and order quality tubing, both annealed and medium-pressure cold drawn – 1/8 hard (unannealed).

Parker believes that proper tubing selection and installation are key to building leak-free, reliable tubing systems.

Parker's MPI™ Fittings have been designed to operate on a wide variety of "medium pressure" applications (6,000 to 15,000 psi).

General Selection Criteria

The data tables in this section will help you select the tubing that best satisfies the needs of the application.

The most important consideration in the selection of suitable tubing for any application is the compatibility of the tubing materials with the media to be contained.

System Pressure

The system operating pressure is another important factor in determining the type, and more importantly, the size of tubing to be used. In general, high pressure installations require strong materials such as stainless steel. Tube fitting assemblies should never be pressurized beyond the recommended working pressure.

Temperature Derating Factors

Table 1 indicates derating factors for 316 stainless steel tubing and MPI™ fittings at elevated temperatures.

Table 1

		Temperature Derating Factors (316 Stainless Steel Tubing)									
°F	-425 to 100	200	300	400	500	600	700	800	900	1000	
°C	-254 to 38	93	149	204	260	316	371	427	482	538	
1/8 Hard*	1.000	1.000	1.000	0.960	0.885	0.835	0.795	0.770	0.750	0.740	
Annealed**	1.000	1.000	1.000	0.965	0.895	0.850	0.815	0.795	0.775	0.765	

* Use with 1/8 Hard 316 tubing shown in [Tables 2 and 3 on page 3](#).

** Use with Annealed 316 tubing shown in [Table 4 on page 3](#).

The rating at temperature is the room temperature (RT) pressure rating listed in the catalog multiplied by the Derating Factor at temperature.

Example: 1/4" MPI™ fittings and tubing @ 800°F

Room Temperature Working Pressure
= 15,000 psi (as shown in Table 2)

800°F Temperature Derating Factor
= .770 (1/8 Hard tube) (as shown above)

800°F Working Pressure
= 15,000 x .770 = 11,550 psi

Maximum Allowable Working Pressure Tables

Tables 2, 3 and 4 list the maximum suggested working pressure of various tubing sizes, according to material. Acceptable tubing diameters and wall thicknesses are those for which a rating is listed. Combinations which do not have a pressure rating are not recommended for use with MPI™ Fittings.

MPI™ Tubing

MPI™ tubing is marked "MPI" and is designed to provide optimum performance for MPI™ fittings. MPI™ tubing is nominal OD $\pm .003$ " 316 seamless stainless steel, cold drawn – 1/8 hard (unannealed) tubing. Tensile strength is approximately 40% higher than annealed tubing.

Table 2 – 316 Stainless Steel (Seamless / Unannealed – 1/8 Hard)

Tube Size (in.)	Nominal OD (in.)	Nominal ID (in.)	Working Pressure (psi)	MPI™ Tube Part No.
1/4	.250	.125	15,000	4-240 MPITube-SS-15K
3/8	.375	.219	15,000	6-240 MPITube-SS-15K
9/16	.562	.344	15,000	9-240 MPITube-SS-15K
3/4	.750	.469	15,000	12-240 MPITube-SS-15K
1	1.000	.656	12,500	16-240 MPITube-SS-12K

NOTE: Working pressures calculated using an allowable stress of 35,000 psi for 1/8 hard 316 stainless steel tubing with a minimum tensile strength of 105,000 psi.

NOTE: Sizes 3/4" & 1" require hydraulic presetting when used with MPI™ fittings.

***Consult factory for pressure tables regarding other materials.**

Cone & Thread Tubing

Cone & Thread (C&T) tubing is available as 1/8 hard 316 seamless stainless steel tubing and is designed to work with existing C&T fittings. C&T tubing has an undersized OD by as much as .010" to better facilitate the coning and threading operations required for use with C&T fittings. MPI™ fittings work effectively with C&T tubing as listed below but require hydraulic presetting for optimum performance.

Table 3 – 316 Stainless Steel (Undersized OD, Seamless / Unannealed – 1/8 Hard)

Tube Size (in.)	Maximum OD (in.)	Nominal ID (in.)	Working Pressure (psi)	Tube Size (in.)	Maximum OD (in.)	Nominal ID (in.)	Working Pressure (psi)
1/4	.250	.109	12,500	9/16	.562	.359	10,000
3/8	.375	.203	12,500	3/4	.750	.516	10,000
9/16	.562	.312	12,500	1	1.000	.688	10,000

Instrumentation Grade Heavy Wall Tubing

Table 4 – 316 Stainless Steel (Seamless / Annealed)

Tube Size (in.)	Tube Wall Thickness (in.)								
	.065	.083	.095	.109	.120	.134	.156	.188	.220
Working Pressure (psi)									
1/4	10,300	13,300							
3/8	6,600	8,600	10,000	11,700					
1/2		6,700	7,800	9,100	10,000	11,400			
3/4				5,800	6,400	7,300	8,600	10,600	
1					4,700	5,300	6,200	7,700	9,200

NOTE: Working pressures calculated using an allowable stress of 20,000 psi for annealed 316 stainless steel tubing with a nominal O.D. tolerance of $\pm .005$ ".

FBMP7 MPI™ to Male NPT Connector

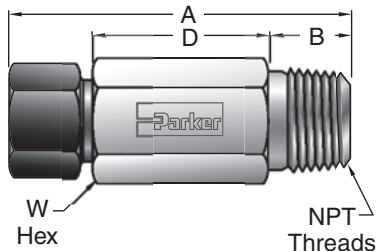

Parker Part No.	Inches						Working Pressure (PSIG)
	MPI™ Size	NPT Thread	A	B	D	W Hex	
4-2 FBMP7	1/4	1/8 - 27	1.91	.38	1.03	5/8	15,000
4-4 FBMP7	1/4	1/4 - 18	2.10	.57	1.03	5/8	15,000
4-6 FBMP7	1/4	3/8 - 18	2.00	.57	.93	3/4	15,000
4-8 FBMP7	1/4	1/2 - 14	2.17	.76	.91	7/8	15,000
6-4 FBMP7	3/8	1/4 - 18	2.43	.57	1.24	3/4	15,000
6-6 FBMP7	3/8	3/8 - 18	2.43	.57	1.24	3/4	15,000
6-8 FBMP7	3/8	1/2 - 14	2.48	.76	1.10	7/8	15,000
8-6 FBMP7	1/2	3/8 - 18	2.85	.57	1.60	1	15,000
8-8 FBMP7	1/2	1/2 - 14	2.81	.76	1.37	1	15,000
9-6 FBMP7	9/16	3/8 - 18	2.91	.57	1.59	1 1/16	15,000
9-8 FBMP7	9/16	1/2 - 14	3.04	.76	1.53	1 1/16	15,000
12-8 FBMP7	3/4	1/2 - 14	3.85	.76	2.21	1 3/8	15,000
12-12 FBMP7	3/4	3/4 - 14	3.46	.76	1.82	1 3/8	10,000
16-12 FBMP7	1	3/4 - 14	4.53	.76	2.64	1 3/4	10,000
16-16 FBMP7	1	1 - 11.5	4.58	.95	2.50	1 3/4	10,000

XHBMP7 37° Flare to MPI™ Connector

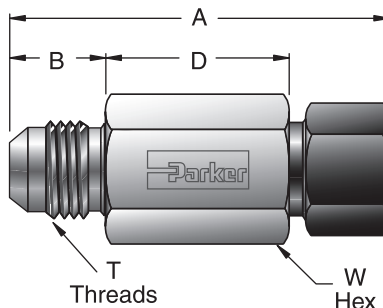

Parker Part No.	Inches							Working Pressure (PSIG)
	37° Flare Adapter	MPI™ Size	A	B	D	T Thread	W Hex	
4-4 XHBMP7	1/4	1/4	2.08	.55	1.03	7/16 - 20	5/8	15,000
4-6 XHBMP7	1/4	3/8	2.54	.55	1.37	7/16 - 20	3/4	15,000
4-8 XHBMP7	1/4	1/2	2.90	.55	1.66	7/16 - 20	1	15,000
4-9 XHBMP7	1/4	9/16	2.96	.55	1.66	7/16 - 20	1 1/16	15,000
6-4 XHBMP7	3/8	1/4	1.97	.56	.92	9/16 - 18	5/8	12,500
6-6 XHBMP7	3/8	3/8	2.24	.56	1.06	9/16 - 18	3/4	12,500
6-8 XHBMP7	3/8	1/2	2.90	.56	1.66	9/16 - 18	1	12,500
6-9 XHBMP7	3/8	9/16	2.97	.56	1.66	9/16 - 18	1 1/16	12,500
8-6 XHBMP7	1/2	3/8	2.34	.66	1.06	3/4 - 16	13/16	12,500
8-8 XHBMP7	1/2	1/2	2.69	.66	1.34	3/4 - 16	1	12,500
8-9 XHBMP7	1/2	9/16	2.77	.66	1.36	3/4 - 16	1 1/16	12,500
8-12 XHBMP7	1/2	3/4	3.38	.86	1.63	1-1/16 - 12	1 3/8	12,500
16-16 XHBMP7	1	1	4.23	.91	2.19	1-5/16 - 12	1 3/4	7,200

MPI™ FITTINGS

MP7H2BX 37° Flare Bulkhead to MPI™ Connector

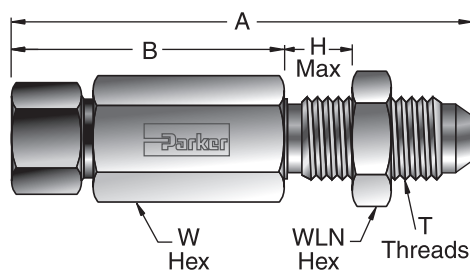

Parker Part No.	Inches								Working Pressure (PSIG)
	MPI™ Size	37° Flare Adapter	A	C	H Max	T Thread	WLN Hex	W Hex	
4-4 MP7H2BX	1/4	1/4	2.76	1.53	.40	7/16 - 20	11/16	5/8	15,000
6-6 MP7H2BX	3/8	3/8	3.24	1.93	.48	9/16 - 18	13/16	3/4	12,500
8-8 MP7H2BX	1/2	1/2	3.44	1.97	.50	3/4 - 16	1	1	12,500
9-8 MP7H2BX	9/16	1/2	3.76	2.29	.50	3/4 - 16	1	1 1/16	12,500

* Bulkhead hole approximately 1/64" (.015") larger than thread major diameter.

X41HBMP7 High Pressure to MPI™ Connector

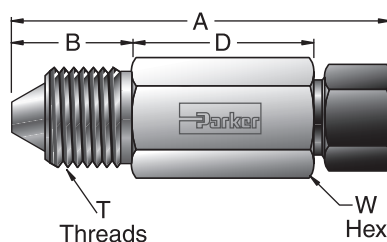

Parker Part No.	Inches							Working Pressure (PSIG)
	High Pressure Adapter	MPI™ Size	A	B	D	T Thread	W Hex	
4-4 X41HBMP7	1/4	1/4	2.25	.72	1.03	9/16 - 18	5/8	15,000
4-6 X41HBMP7	1/4	3/8	2.71	.72	1.37	9/16 - 18	3/4	15,000
6-4 X41HBMP7	3/8	1/4	2.52	.92	1.10	3/4 - 16	13/16	15,000
6-6 X41HBMP7	3/8	3/8	2.92	.92	1.37	3/4 - 16	13/16	15,000
6-9 X41HBMP7	3/8	9/16	3.37	.92	1.70	3/4 - 16	1 1/16	15,000
9-6 X41HBMP7	9/16	3/8	3.12	1.13	1.37	1 1/8 - 12	1 3/16	15,000
9-9 X41HBMP7	9/16	9/16	3.58	1.13	1.70	1 1/8 - 12	1 3/16	15,000
9-12 X41HBMP7	9/16	3/4	4.03	1.13	2.02	1 1/8 - 12	1 3/8	15,000

X42HBMP7 Medium Pressure to MPI™ Connector

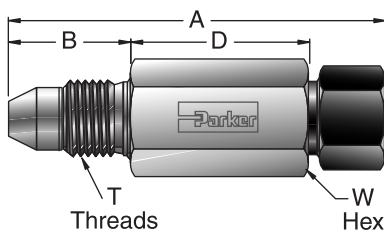

Parker Part No.	Inches							Working Pressure (PSIG)
	Medium Pressure Adapter	MPI™ Size	A	B	D	T Thread	W Hex	
4-4 X42HBMP7	1/4	1/4	2.34	.81	1.03	7/16 - 20	5/8	15,000
4-6 X42HBMP7	1/4	3/8	2.80	.81	1.37	7/16 - 20	3/4	15,000
4-9 X42HBMP7	1/4	9/16	3.31	.81	1.75	7/16 - 20	1-1/16	15,000
6-4 X42HBMP7	3/8	1/4	2.47	.94	1.03	9/16 - 18	3/4	15,000
6-6 X42HBMP7	3/8	3/8	2.93	.94	1.37	9/16 - 18	3/4	15,000
6-8 X42HBMP7	3/8	1/2	3.28	.94	1.65	9/16 - 18	1	15,000
6-9 X42HBMP7	3/8	9/16	3.44	.94	1.75	9/16 - 18	1-1/16	15,000
9-4 X42HBMP7	9/16	1/4	2.56	1.13	.93	13/16 - 16	7/8	15,000
9-6 X42HBMP7	9/16	3/8	2.85	1.13	1.10	13/16 - 16	7/8	15,000
9-8 X42HBMP7	9/16	1/2	3.16	1.13	1.35	13/16 - 16	1	15,000
9-9 X42HBMP7	9/16	9/16	3.41	1.13	1.54	13/16 - 16	1-1/16	15,000
9-12 X42HBMP7	9/16	3/4	4.20	1.13	2.19	13/16 - 16	1-3/8	15,000
12-9 X42HBMP7	3/4	9/16	3.55	1.31	1.35	3/4 - 14 NPS	1-1/16	15,000
12-12 X42HBMP7	3/4	3/4	4.15	1.31	1.96	3/4 - 14 NPS	1-3/8	15,000
12-16 X42HBMP7	3/4	1	5.27	1.31	2.83	3/4 - 14 NPS	1-3/4	12,500

GBMP7 MPI™ Female NPT Connector

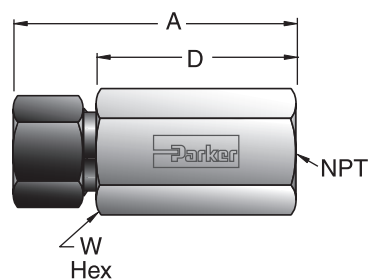

Parker Part No.	Inches					Working Pressure (PSIG)
	MPI™ Size	NPT Thread	A	D	W Hex	
4-2 GBMP7	1/4	1/8 - 27	2.06	1.56	13/16	15,000
4-4 GBMP7	1/4	1/4 - 18	2.25	1.75	1	15,000
4-6 GBMP7	1/4	3/8 - 18	2.35	1.85	1 1/8	15,000
4-8 GBMP7	1/4	1/2 - 14	2.58	2.08	1 3/8	15,000
6-2 GBMP7	3/8	1/8 - 27	2.37	1.74	13/16	15,000
6-4 GBMP7	3/8	1/4 - 18	2.56	1.93	1	15,000
6-6 GBMP7	3/8	3/8 - 18	2.66	2.03	1 1/8	15,000
6-8 GBMP7	3/8	1/2 - 14	2.87	2.24	1 3/8	15,000
8-4 GBMP7	1/2	1/4 - 18	2.89	2.20	1	15,000
8-6 GBMP7	1/2	3/8 - 18	2.99	2.30	1 1/8	15,000
8-8 GBMP7	1/2	1/2 - 14	3.20	2.51	1 3/8	15,000
9-4 GBMP7	9/16	1/4 - 18	2.68	2.18	1 3/8	15,000
9-6 GBMP7	9/16	3/8 - 18	2.93	2.30	1 1/8	15,000
9-8 GBMP7	9/16	1/2 - 14	3.26	2.51	1 3/8	15,000
12-8 GBMP7	3/4	1/2 - 14	3.70	2.82	1 3/8	15,000

MPI™ FITTINGS

MP7HBA MPI™ to SAE Male O-Ring Connector

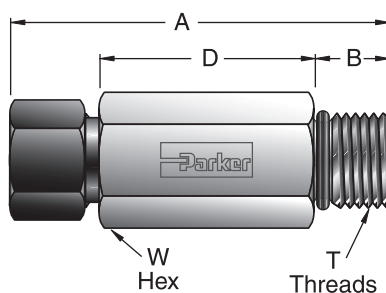

Parker Part No.	Inches							Working Pressure (PSIG)
	MPI™ Size	SAE* End	A	B	D	T Thread	W Hex	
4-4 MP7HBA	1/4	1/4	1.90	.43	.97	7/16 - 20	5/8	12,500
4-6 MP7HBA	1/4	3/8	1.94	.47	.97	9/16 - 18	11/16	12,500
4-8 MP7HBA	1/4	1/2	1.97	.55	.91	3/4 - 16	7/8	12,500
6-4 MP7HBA	3/8	1/4	2.41	.43	1.35	7/16 - 20	3/4	12,500
6-6 MP7HBA	3/8	3/8	2.20	.47	1.10	9/16 - 18	3/4	12,500
6-8 MP7HBA	3/8	1/2	2.23	.55	1.05	3/4 - 16	7/8	12,500
8-4 MP7HBA	1/2	1/4	2.81	.43	1.69	7/16 - 20	1	12,500
8-6 MP7HBA	1/2	3/8	2.82	.47	1.66	9/16 - 18	1	12,500
8-8 MP7HBA	1/2	1/2	2.60	.55	1.36	3/4 - 16	1	12,500
9-6 MP7HBA	9/16	3/8	2.89	.47	1.67	9/16 - 18	1 1/16	12,500
9-8 MP7HBA	9/16	1/2	2.89	.55	1.59	3/4 - 16	1 1/16	12,500

*All male o-ring ends for MPI™ fittings are heavy duty and comply with SAE J1926-2. This end has maximum thread engagement for strength and requires the minimum full thread engagement specified in SAE J1926 for the female port. Standard O-ring material is Nitrile #N0552-90.

M40HBMP7 Type “M” High Pressure Hose to MPI™ Connector

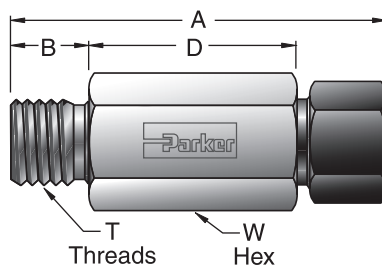

Parker Part No.	Inches							Working Pressure (PSIG)
	HOSE* Adapter	MPI™ Size	A	B	D	T Thread	W Hex	
6-4 M40HBMP7	- 6	1/4	2.03	.50	1.03	9/16 - 18	5/8	15,000
6-6 M40HBMP7	- 6	3/8	2.45	.50	1.32	9/16 - 18	3/4	15,000
8-6 M40HBMP7	- 8	3/8	2.57	.63	1.32	3/4 - 16	13/16	15,000
8-8 M40HBMP7	- 8	1/2	2.90	.63	1.59	3/4 - 16	1	15,000
8-9 M40HBMP7	- 8	9/16	2.97	.63	1.59	3/4 - 16	1-1/16	15,000
10-4 M40HBMP7	- 10	1/4	2.39	.75	1.14	7/8 - 14	15/16	15,000
10-6 M40HBMP7	- 10	3/8	2.72	.75	1.34	7/8 - 14	15/16	15,000
11-8 M40HBMP7	- 11	1/2	2.89	.63	1.58	1 - 12	1-1/16	15,000
11-9 M40HBMP7	- 11	9/16	2.95	.63	1.58	1 - 12	1-1/16	15,000
11-12 M40HBMP7	- 11	3/4	3.59	.63	2.08	1 - 12	1-3/8	15,000
16-16 M40HBMP7	- 16	1	3.88	.63	2.13	1-5/16 - 12	1-3/4	12,500

* Adapts to Type “M” Swivel Hose Connection.

GH2BMP7 MPI™ Bulkhead to Female NPT Connector

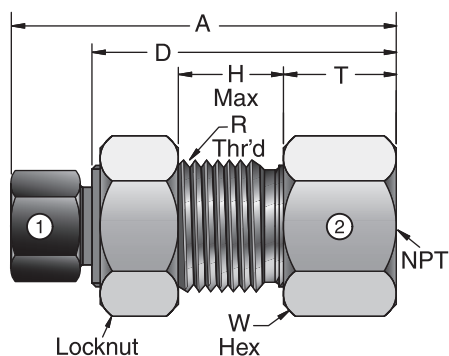

Parker Part No.	Inches								Working Pressure (PSIG)
	MPI™ Size	NPT Thread	A	D	H Max.	R Thread	T	W Hex	
4-4 GH2BMP7	1/4	1/4 - 18	2.38	1.88	.56	3/4 - 20	.75	1	15,000
6-8 GH2BMP7	3/8	1/2 - 14	3.13	2.50	.63	7/8 - 20	1.25	1-3/8	15,000
6-12 GH2BMP7	3/8	3/4 - 14	3.19	2.56	.63	7/8 - 20	1.31	1-1/2	10,000
8-12 GH2BMP7	1/2	3/4 - 14	3.50	2.81	.75	1-1/8 - 20	1.31	1-1/2	10,000
9-4 GH2BMP7	9/16	1/4 - 18	2.82	2.07	.63	1-1/8 - 20	.69	1-3/8	15,000

* Bulkhead hole approximately 1/64" (.015") larger than thread major diameter.

HBMP7 MPI™ Union Connector

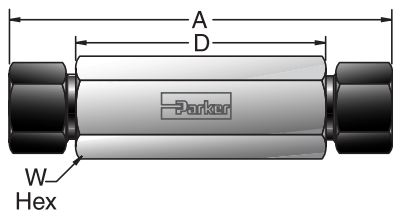

Parker Part No.	Inches				Working Pressure (PSIG)
	MPI™ Size	A	D	W Hex	
4-4 HBMP7	1/4	2.88	1.88	5/8	15,000
6-4 HBMP7	3/8 - 1/4	3.32	2.19	3/4	15,000
6-6 HBMP7	3/8	3.44	2.19	3/4	15,000
8-4 HBMP7	1/2 - 1/4	3.88	2.70	1	15,000
8-6 HBMP7	1/2 - 3/8	4.01	2.70	1	15,000
8-8 HBMP7	1/2	4.07	2.70	1	15,000
9-4 HBMP7	9/16 - 1/4	3.95	2.70	1-1/16	15,000
9-6 HBMP7	9/16 - 3/8	4.07	2.70	1-1/16	15,000
9-8 HBMP7	9/16 - 1/2	4.13	2.70	1-1/16	15,000
9-9 HBMP7	9/16	4.20	2.70	1-1/16	15,000
12-6 HBMP7	3/4 - 3/8	4.76	3.25	1-3/8	15,000
12-9 HBMP7	3/4 - 9/16	5.15	3.51	1-3/8	15,000
12-12 HBMP7	3/4	5.08	3.31	1-3/8	15,000
16-16 HBMP7	1	6.52	4.25	1-3/4	12,500

WBMP7 MPI™ Bulkhead Union Connector

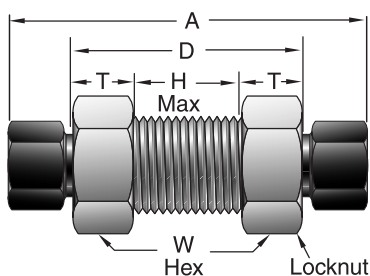

Parker Part No.	Inches							Working Pressure (PSIG)
	MPI™ Size	A	D	H Max	T	*R Threads	W Hex	
4-4 WBMP7	1/4	2.88	1.88	.88	.50	3/4-20	1	15,000
6-6 WBMP7	3/8	3.44	2.19	1.07	.56	7/8-20	1 1/8	15,000
8-8 WBMP7	1/2	4.07	2.70	1.32	.69	1 1/8-20	1 3/8	15,000
8-9 WBMP7	1/2 - 9/16	4.20	2.70	1.32	.69	1 1/8-20	1 3/8	15,000
9-8 WBMP7	9/16 - 1/2	4.20	2.70	1.32	.69	1 1/8-20	1 3/8	15,000
9-9 WBMP7	9/16	4.20	2.70	1.32	.69	1 1/8-20	1 3/8	15,000
12-12 WBMP7	3/4	5.08	3.31	1.56	.88	1 7/16-18	1 7/8	15,000
16-16 WBMP7	1	6.52	4.25	2.00	1.13	1 7/8-12	2 1/2	12,500

* Bulkhead hole approximately 1/64" (.015") larger than thread major diameter.

GM7 MPI™ Male End to Female NPT

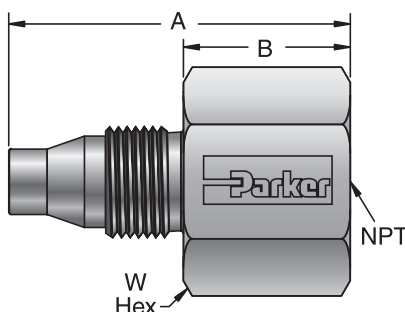

Parker Part No.	Inches						Working Pressure (PSIG)
	MPI™ Male Thread ¹	Female NPT End	A	B	NPT Thread	W Hex	
4-4 GM7	1/4	1/4	1.73	.85	1/4 - 18	1	15,000
4-6 GM7	1/4	3/8	1.83	.95	3/8 - 18	1 1/8	15,000
6-4 GM7	3/8	1/4	1.84	.85	1/4 - 18	1	15,000
6-6 GM7	3/8	3/8	1.94	.95	3/8 - 18	1 1/8	15,000
6-8 GM7	3/8	1/2	2.17	1.17	1/2 - 14	1 3/8	15,000
8-4 GM7	1/2	1/4	2.05	.85	1/4 - 18	1	15,000
8-6 GM7	1/2	3/8	2.15	.95	3/8 - 18	1 1/8	15,000
8-8 GM7	1/2	1/2	2.37	1.17	1/2 - 14	1 3/8	15,000
9-4 GM7	9/16	1/4	2.05	.85	1/4 - 18	1	15,000
9-6 GM7	9/16	3/8	2.15	.95	3/8 - 18	1 1/8	15,000
9-8 GM7	9/16	1/2	2.37	1.17	1/2 - 14	1 3/8	15,000
12-4 GM7	3/4	1/4	2.17	.75	1/4 - 18	1 1/4	15,000
12-6 GM7	3/4	3/8	2.17	.75	3/8 - 18	1 1/4	15,000
12-8 GM7	3/4	1/2	2.59	1.17	1/2 - 14	1 3/8	15,000

¹Assemble 1/4 to 1/2 turn from finger tight & lubricate threads & taper before each remake.

GM7 MPI™ Male End to High Pressure C&T Port

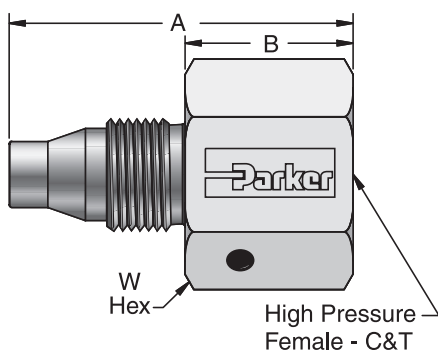

Parker Part No.	Inches						Working Pressure (PSIG)
	MPI™ Male Thread ¹	High Press C&T Port	A	B	C&T Thread	W Hex	
4-4HF GM7	1/4	1/4	1.57	.69	9/16 - 18	3/4	15,000
6-4HF GM7	3/8	1/4	1.68	.69	9/16 - 18	3/4	15,000
6-6HF GM7	3/8	3/8	1.87	.88	3/4 - 16	1	15,000
8-4HF GM7	1/2	1/4	1.89	.69	9/16 - 18	15/16	15,000
8-6HF GM7	1/2	3/8	2.07	.88	3/4 - 16	1	15,000
9-4HF GM7	9/16	1/4	1.89	.69	9/16 - 18	1	15,000
9-6HF GM7	9/16	3/8	2.07	.88	3/4 - 16	1	15,000
12-4HF GM7	3/4	1/4	2.17	.75	9/16 - 18	1 1/4	15,000
12-6HF GM7	3/4	3/8	2.30	.88	3/4 - 16	1 1/4	15,000

¹Assemble 1/4 to 1/2 turn from finger tight & lubricate threads & taper before each remake.

T7HBT7 MPI™ Tube Port Connector

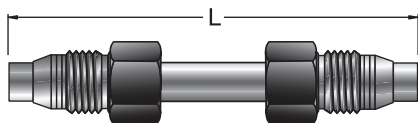

Parker Part No.	Inches		Working Pressure (PSIG)
	Tube Size	L	
* 4 T7HBT7-SS	1/4	2.72	15,000
4 T7HBT7-SS 4.0	1/4	4.00	15,000
4 T7HBT7-SS 6.0	1/4	6.00	15,000
4 T7HBT7-SS 8.0	1/4	8.00	15,000
4 T7HBT7-SS 10.0	1/4	10.00	15,000
4 T7HBT7-SS 12.0	1/4	12.00	15,000
* 6 T7HBT7-SS	3/8	3.19	15,000
6 T7HBT7-SS 4.0	3/8	4.00	15,000
6 T7HBT7-SS 6.0	3/8	6.00	15,000
6 T7HBT7-SS 8.0	3/8	8.00	15,000
6 T7HBT7-SS 10.0	3/8	10.00	15,000
6 T7HBT7-SS 12.0	3/8	12.00	15,000
* 9 T7HBT7-SS	9/16	3.85	15,000
9 T7HBT7-SS 6.0	9/16	6.00	15,000
9 T7HBT7-SS 8.0	9/16	8.00	15,000
9 T7HBT7-SS 10.0	9/16	10.00	15,000
9 T7HBT7-SS 12.0	9/16	12.00	15,000
* 12 T7HBT7-SS	3/4	4.55	15,000
12 T7HBT7-SS 6.0	3/4	6.00	15,000
12 T7HBT7-SS 8.0	3/4	8.00	15,000
12 T7HBT7-SS 10.0	3/4	10.00	15,000
12 T7HBT7-SS 12.0	3/4	12.00	15,000

Assemble 1/2 turn from finger tight.

* Same Assembled Length as [MP7PC](#).

T7HF MPI™ Tube Stub to Male NPT Pipe

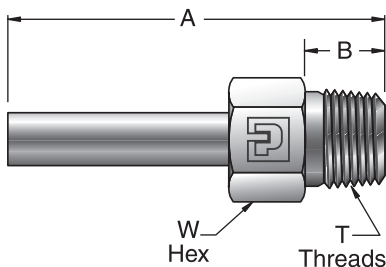

Parker Part No.	Inches						Working Pressure (PSIG)
	MPI™ Tube Stub	Male NPT End	A	B	NPT Thread	W Hex	
4-4 T7HF	1/4	1/4	2.32	.57	1/4 - 18	5/8	15,000
4-6 T7HF	1/4	3/8	2.44	.57	3/8 - 18	3/4	15,000
4-8 T7HF	1/4	1/2	2.76	.76	1/2 - 14	7/8	15,000
6-4 T7HF	3/8	1/4	2.56	.57	1/4 - 18	5/8	15,000
6-6 T7HF	3/8	3/8	2.68	.57	3/8 - 18	3/4	15,000
6-8 T7HF	3/8	1/2	2.99	.76	1/2 - 14	7/8	15,000
8-4 T7HF	1/2	1/4	2.82	.57	1/4 - 18	5/8	15,000
8-6 T7HF	1/2	3/8	2.95	.57	3/8 - 18	3/4	15,000
8-8 T7HF	1/2	1/2	3.26	.76	1/2 - 14	7/8	15,000
9-4 T7HF	9/16	1/4	2.88	.57	1/4 - 18	5/8	15,000
9-6 T7HF	9/16	3/8	3.01	.57	3/8 - 18	3/4	15,000
9-8 T7HF	9/16	1/2	3.32	.76	1/2 - 14	7/8	15,000
9-12 T7HF	9/16	3/4	3.43	.76	3/4 - 14	1 1/8	10,000
12-8 T7HF	3/4	1/2	3.67	.76	1/2 - 14	7/8	15,000
12-12 T7HF	3/4	3/4	3.80	.76	3/4 - 14	1 1/8	10,000

Add "-Z6" to part number for part assembled with preset ferrules and nuts.

XHT7 37° Flare to MPI™ Tube Stub

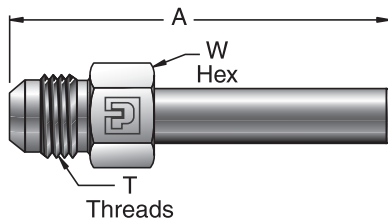

Parker Part No.	Inches					Working Pressure (PSIG)
	37° Flare Adapter Size	MPI™ Tube Stub	A	T Thread	W Hex	
4-4 XHT7	1/4	1/4	2.24	7/16 - 20	1/2	15,000
4-6 XHT7	1/4	3/8	2.47	7/16 - 20	1/2	15,000
6-4 XHT7	3/8	1/4	2.37	9/16 - 18	5/8	12,500
6-6 XHT7	3/8	3/8	2.60	9/16 - 18	5/8	12,500
6-8 XHT7	3/8	1/2	2.87	9/16 - 18	5/8	12,500
6-9 XHT7	3/8	9/16	2.93	9/16 - 18	5/8	12,500
8-6 XHT7	1/2	3/8	2.77	3/4 - 16	13/16	12,500
8-8 XHT7	1/2	1/2	3.04	3/4 - 16	13/16	12,500
8-9 XHT7	1/2	9/16	3.10	3/4 - 16	13/16	12,500

Add "-Z6" to part number for part assembled with preset ferrules and nuts.

X41HT7 High Pressure to MPI™ Tube Stub

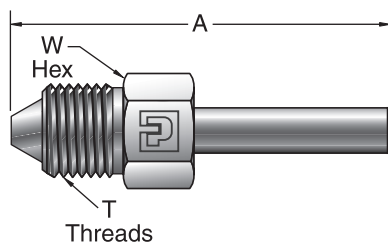

Parker Part No.	Inches					Working Pressure (PSIG)
	High Pressure Adapter Size	MPI™ Tube Stub	A	T Thread	W Hex	
4-4 X41HT7	1/4	1/4	2.59	9/16 - 18	5/8	15,000
4-6 X41HT7	1/4	3/8	2.83	9/16 - 18	5/8	15,000
4-8 X41HT7	1/4	1/2	3.10	9/16 - 18	5/8	15,000
4-9 X41HT7	1/4	9/16	3.16	9/16 - 18	5/8	15,000
6-4 X41HT7	3/8	1/4	2.92	3/4 - 16	13/16	15,000
6-6 X41HT7	3/8	3/8	3.16	3/4 - 16	13/16	15,000
6-8 X41HT7	3/8	1/2	3.43	3/4 - 16	13/16	15,000
6-9 X41HT7	3/8	9/16	3.49	3/4 - 16	13/16	15,000
9-4 X41HT7	9/16	1/4	3.25	1 1/8 - 12	1-3/16	15,000
9-6 X41HT7	9/16	3/8	3.49	1 1/8 - 12	1-3/16	15,000
9-8 X41HT7	9/16	1/2	3.75	1 1/8 - 12	1-3/16	15,000
9-9 X41HT7	9/16	9/16	3.82	1 1/8 - 12	1-3/16	15,000

Add "-Z6" to part number for part assembled with preset ferrules and nuts.

X47HT7 Medium Pressure Port Connector to MPI™ Tube Stub

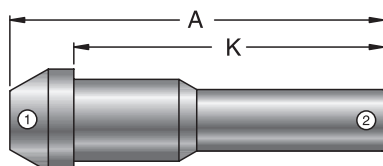

Parker Part No.	Inches				Working Pressure (PSIG)
	MP Port Connector #1	MPI™ Tube Stub #2	A	K	
9-6 X47HT7	9/16	3/8	3.21	1.61	15,000
9-9 X47HT7	9/16	9/16	3.53	3.03	15,000
12-9 X47HT7	3/4	9/16	3.72	1.94	15,000
12-12 X47HT7	3/4	3/4	4.07	3.44	15,000
16-9 X47HT7	1	9/16	4.23	3.44	15,000
16-12 X47HT9	1	3/4	4.57	3.79	15,000
16-16 X47HT10	1	1	5.19	4.41	12,500

End # 1 must be used with a Medium Pressure Gland.

Add "-Z6" to part number for part assembled with preset ferrules and nuts.

X42HT7 Medium Pressure to MPI™ Tube Stub

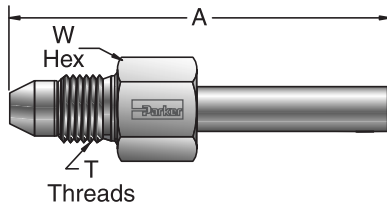

Parker Part No.	Inches					Working Pressure (PSIG)
	Medium Pressure Adapter Size	MPI™ Tube Stub	A	T Thread	W Hex	
4-4 X42HT7	1/4	1/4	2.68	7/16 - 20	5/8	15,000
4-6 X42HT7	1/4	3/8	2.92	7/16 - 20	5/8	15,000
4-8 X42HT7	1/4	1/2	3.18	7/16 - 20	5/8	15,000
4-9 X42HT7	1/4	9/16	3.25	7/16 - 20	5/8	15,000
6-4 X42HT7	3/8	1/4	2.94	9/16 - 18	3/4	15,000
6-6 X42HT7	3/8	3/8	3.17	9/16 - 18	3/4	15,000
6-8 X42HT7	3/8	1/2	3.44	9/16 - 18	3/4	15,000
6-9 X42HT7	3/8	9/16	3.50	9/16 - 18	3/4	15,000
9-4 X42HT7	9/16	1/4	3.25	13/16 - 16	7/8	15,000
9-6 X42HT7	9/16	3/8	3.49	13/16 - 16	7/8	15,000
9-8 X42HT7	9/16	1/2	3.75	13/16 - 16	7/8	15,000
9-9 X42HT7	9/16	9/16	3.81	13/16 - 16	7/8	15,000
9-12 X42HT7	9/16	3/4	4.16	13/16 - 16	7/8	15,000
12-9 X42HT7	3/4	9/16	4.00	3/4 - 14 NPS	1 1/8	15,000
12-12 X42HT7	3/4	3/4	4.35	3/4 - 14 NPS	1 1/8	15,000

Add "-Z6" to part number for part assembled with preset ferrules and nuts.

T7HOA MPI™ Tube Stub to Male SAE O-ring

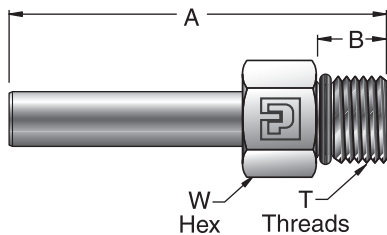

Parker Part No.	Inches						Working Pressure (PSIG)
	MPI™ Tube Stub	SAE O-Ring End	A	B	T Thread	W Hex	
4-4 T7HOA	1/4	1/4	2.25	.43	7/16 - 20	9/16	12,500
4-6 T7HOA	1/4	3/8	2.35	.47	9/16 - 18	11/16	12,500
4-8 T7HOA	1/4	1/2	2.49	.55	3/4 - 16	7/8	12,500
6-4 T7HOA	3/8	1/4	2.48	.43	7/16 - 20	9/16	12,500
6-6 T7HOA	3/8	3/8	2.58	.47	9/16 - 18	11/16	12,500
6-8 T7HOA	3/8	1/2	2.72	.55	3/4 - 16	7/8	12,500
8-4 T7HOA	1/2	1/4	2.75	.43	7/16 - 20	9/16	12,500
8-6 T7HOA	1/2	3/8	2.85	.47	9/16 - 18	11/16	12,500
8-8 T7HOA	1/2	1/2	2.99	.55	3/4 - 16	7/8	12,500
9-4 T7HOA	9/16	1/4	2.81	.43	7/16 - 20	5/8	12,500
9-6 T7HOA	9/16	3/8	2.91	.47	9/16 - 18	11/16	12,500
9-8 T7HOA	9/16	1/2	3.05	.55	3/4 - 16	7/8	12,500

Add "-Z6" to part number for part assembled with preset ferrules and nuts.

* All male o-ring ends for MPI™ fittings are heavy duty and comply with SAE J1926-2. This end has maximum thread engagement for strength and requires the minimum full thread engagement specified in SAE J9126 for the female port. Standard O-ring material is Nitrile #N0552-90.

M40HT7 Type "M" High Pressure Hose Adapter to MPI™ Tube Stub

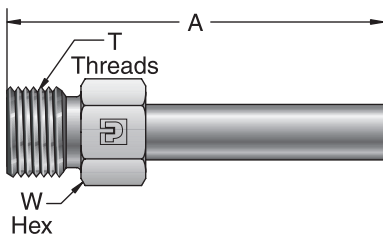

Parker Part No.	Inches					Working Pressure (PSIG)
	Hose* Adapter Size	MPI™ Tube Stub	A	T Thread	W Hex	
6-4 M40HT7	-6	1/4	2.31	9/16 - 18	5/8	15,000
6-6 M40HT7	-6	3/8	2.55	9/16 - 18	5/8	15,000
8-6 M40HT7	-8	3/8	2.74	3/4 - 16	13/16	15,000
8-9 M40HT7	-8	9/16	3.12	3/4 - 16	13/16	15,000
11-6 M40HT7	-11	3/8	2.99	1 - 12	1 1/16	15,000
11-9 M40HT7	-11	9/16	3.31	1 - 12	1 1/16	15,000
11-12 M40HT7	-11	3/4	3.66	1 - 12	1 1/16	15,000
16-12 M40HT7	-16	3/4	3.91	1 5/16 - 12	1 3/8	15,000
16-16 M40HT7	-16	1	4.51	1 5/16 - 12	1 3/8	12,500

Add "-Z6" to part number for part assembled with preset ferrules and nuts.

TRBMP7 MPI™ Tube Stub Reducer

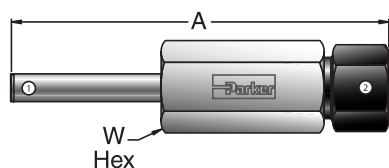

Parker Part No.	Inches				Working Pressure (PSIG)
	MPI™ Tube Stub #1	MPI™ Size #2	A	W Hex	
4-6 TRBMP7	1/4	3/8	3.49	3/4	15,000
4-8 TRBMP7	1/4	1/2	3.94	1	15,000
4-9 TRBMP7	1/4	9/16	4.00	1 1/16	15,000
6-4 TRBMP7	3/8	1/4	3.30	5/8	15,000
6-8 TRBMP7	3/8	1/2	4.17	1	15,000
6-9 TRBMP7	3/8	9/16	4.24	1 1/16	15,000
8-4 TRBMP7	1/2	1/4	3.56	5/8	15,000
8-6 TRBMP7	1/2	3/8	3.99	3/4	15,000
9-4 TRBMP7	9/16	1/4	3.63	5/8	15,000
9-6 TRBMP7	9/16	3/8	4.06	3/4	15,000
9-12 TRBMP7	9/16	3/4	4.97	1 3/8	15,000
12-4 TRBMP7	3/4	1/4	4.17	13/16	15,000
12-6 TRBMP7	3/4	3/8	4.42	13/16	15,000
12-9 TRBMP7	3/4	9/16	4.82	1 1/16	15,000

Add "-Z6" to part number for part assembled with preset ferrules and nuts.

T7HG MPI™ Tube Stub to Female NPT Pipe

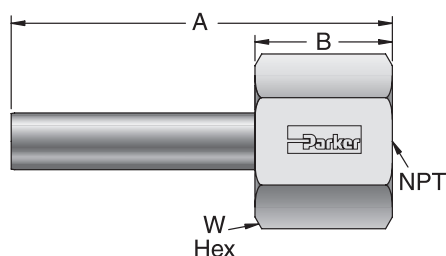

Parker Part No.	Inches						Working Pressure (PSIG)
	MPI™ Tube Stub	Female NPT End	A	B	NPT Thread	W Hex	
4-2 T7HG	1/4	1/8	2.09	.72	1/8 - 27	13/16	15,000
4-4 T7HG	1/4	1/4	2.28	.91	1/4 - 18	1	15,000
4-8 T7HG	1/4	1/2	2.64	1.27	1/2 - 14	1 3/8	15,000
6-2 T7HG	3/8	1/8	2.33	.72	1/8 - 27	13/16	15,000
6-4 T7HG	3/8	1/4	2.52	.91	1/4 - 18	1	15,000
6-8 T7HG	3/8	1/2	2.88	1.27	1/2 - 14	1 3/8	15,000
8-2 T7HG	1/2	1/8	2.60	.72	1/8 - 27	13/16	15,000
8-4 T7HG	1/2	1/4	2.79	.91	1/4 - 18	1	15,000
8-8 T7HG	1/2	1/2	3.14	1.27	1/2 - 14	1 3/8	15,000
9-4 T7HG	9/16	1/4	2.84	.91	1/4 - 18	1	15,000
9-8 T7HG	9/16	1/2	3.20	1.27	1/2 - 14	1 3/8	15,000
12-8 T7HG	3/4	1/2	3.55	1.27	1/2 - 14	1 3/8	15,000
12-12 T7HG	3/4	3/4	3.60	1.31	3/4 - 11 1/2	1 1/2	10,000
16-16 T7HG	1	1	4.38	1.50	1 - 11 1/2	1 7/8	10,000

Add "-Z6" to part number for part assembled with preset ferrules and nuts.

MP7PC MPI™ Port Connector

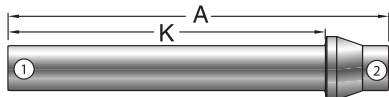

Parker Part No.	Inches				Working Pressure (PSIG)
	MPI™ Tube Stub #1	MPI™ Port #2 ¹	A	K	
4-4 MP7PC	1/4	1/4	2.69	2.23	15,000
4-6 MP7PC	1/4	3/8	2.93	2.40	15,000
6-6 MP7PC	3/8	3/8	3.17	2.64	15,000
6-8 MP7PC	3/8	1/2	3.43	2.68	15,000
6-9 MP7PC	3/8	9/16	3.50	2.75	15,000
8-8 MP7PC	1/2	1/2	3.70	2.95	15,000
9-9 MP7PC	9/16	9/16	3.82	3.07	15,000
9-12 MP7PC	9/16	3/4	4.17	3.32	15,000
12-12 MP7PC	3/4	3/4	4.52	3.67	15,000
12-16 MP7PC	3/4	1	5.12	4.07	12,500
16-16 MP7PC	1	1	5.74	4.70	12,500

¹ Assemble 1/4 to 1/2 turn from finger tight.
Add "-Z6" to part number for part assembled with preset ferrules and nuts.

NBMP7 45° MPI™ Union Elbow

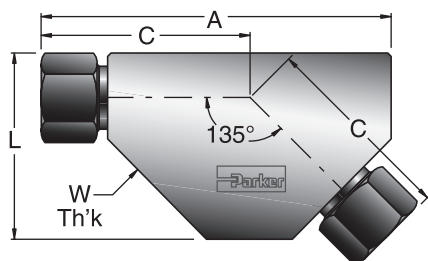

Parker Part No.	Inches					Working Pressure (PSIG)
	MPI™ Size	A	C	L	W Th'k	
4-4 NBMP7	1/4	2.56	1.50	1.38	5/8	15,000
6-6 NBMP7	3/8	3.10	1.81	1.63	3/4	15,000
8-8 NBMP7	1/2	3.76	2.18	2.13	1	15,000
9-9 NBMP7	9/16	3.82	2.24	2.13	1	15,000
12-12 NBMP7	3/4	4.76	2.82	2.63	1 3/8	15,000

MPI™ FITTINGS

T7NBT7 45° MPI™ Tube Stub Elbow

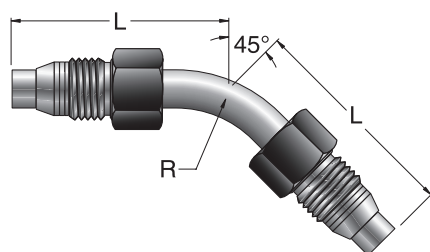

Parker Part No.	Inches			Working Pressure (PSIG)
	Tube Size	L	R	
4 T7NBT7-SS	1/4	1.69	0.75	15,000
* 4 T7NBT7-SS 2.9	1/4	2.88	0.75	15,000
4 T7NBT7-SS 6.0	1/4	6.00	0.75	15,000
4 T7NBT7-SS 8.0	1/4	8.00	0.75	15,000
4 T7NBT7-SS 10.0	1/4	10.00	0.75	15,000
4 T7NBT7-SS 12.0	1/4	12.00	0.75	15,000
6 T7NBT7-SS	3/8	2.14	1.25	15,000
* 6 T7NBT7-SS 3.4	3/8	3.42	1.25	15,000
6 T7NBT7-SS 6.0	3/8	6.00	1.25	15,000
6 T7NBT7-SS 8.0	3/8	8.00	1.25	15,000
6 T7NBT7-SS 10.0	3/8	10.00	1.25	15,000
6 T7NBT7-SS 12.0	3/8	12.00	1.25	15,000
9 T7NBT7-SS	9/16	2.77	2.00	15,000
* 9 T7NBT7-SS 4.2	9/16	4.18	2.00	15,000
9 T7NBT7-SS 6.0	9/16	6.00	2.00	15,000
9 T7NBT7-SS 8.0	9/16	8.00	2.00	15,000
9 T7NBT7-SS 10.0	9/16	10.00	2.00	15,000
9 T7NBT7-SS 12.0	9/16	12.00	2.00	15,000
12 T7NBT7-SS	3/4	3.55	3.00	15,000
12 T7NBT7-SS 5.1	3/4	5.11	3.00	15,000
12 T7NBT7-SS 6.0	3/4	6.00	3.00	15,000
12 T7NBT7-SS 8.0	3/4	8.00	3.00	15,000
12 T7NBT7-SS 10.0	3/4	10.00	3.00	15,000
12 T7NBT7-SS 12.0	3/4	12.00	3.00	15,000

Assemble 1/2 turn from finger tight.

* Similar Assembled Lengths as [NBMP7](#) with two (2) [MP7PCs](#).

EBMP7 MPI™ Union Elbow

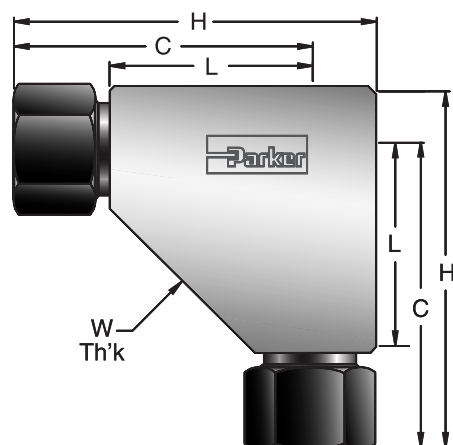

Parker Part No.	MPI™ Size	Inches				Working Pressure (PSIG)
		C	H	L	W Th'k	
4-4 EBMP7	1/4	1.53	1.88	1.03	5/8	15,000
6-6 EBMP7	3/8	1.86	2.25	1.24	3/4	15,000
8-8 EBMP7	1/2	2.22	2.81	1.54	1	15,000
9-9 EBMP7	9/16	2.29	2.88	1.54	1	15,000
12-12 EBMP7	3/4	2.82	3.51	1.94	1 3/8	15,000
16-16 EBMP7	1	3.63	4.51	2.50	1 3/4	12,500

T7EBT7 MPI™ Tube Elbow

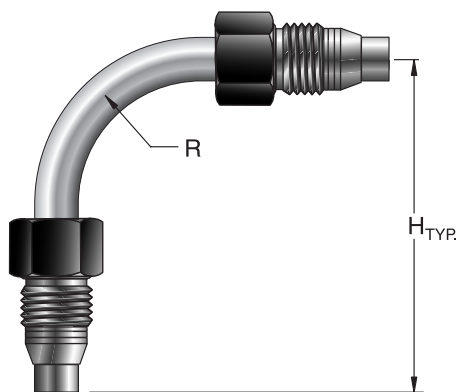

Parker Part No.	Inches			Working Pressure (PSIG)
	Tube Size	H	R	
4 T7EBT7-SS	1/4	2.12	0.75	15,000
* 4 T7EBT7-SS 2.9	1/4	2.91	0.75	15,000
4 T7EBT7-SS 6.0	1/4	6.00	0.75	15,000
4 T7EBT7-SS 8.0	1/4	8.00	0.75	15,000
4 T7EBT7-SS 10.0	1/4	10.00	0.75	15,000
4 T7EBT7-SS 12.0	1/4	12.00	0.75	15,000
6 T7EBT7-SS	3/8	2.88	1.25	15,000
* 6 T7EBT7-SS 3.5	3/8	3.47	1.25	15,000
6 T7EBT7-SS 6.0	3/8	6.00	1.25	15,000
6 T7EBT7-SS 8.0	3/8	8.00	1.25	15,000
6 T7EBT7-SS 10.0	3/8	10.00	1.25	15,000
6 T7EBT7-SS 12.0	3/8	12.00	1.25	15,000
* 9 T7EBT7-SS	9/16	4.22	2.00	15,000
9 T7EBT7-SS 6.0	9/16	6.00	2.00	15,000
9 T7EBT7-SS 8.0	9/16	8.00	2.00	15,000
9 T7EBT7-SS 10.0	9/16	10.00	2.00	15,000
9 T7EBT7-SS 12.0	9/16	12.00	2.00	15,000
12 T7EBT7-SS	3/4	5.31	3.00	15,000
12 T7EBT7-SS 6.0	3/4	6.00	3.00	15,000
12 T7EBT7-SS 8.0	3/4	8.00	3.00	15,000
12 T7EBT7-SS 10.0	3/4	10.00	3.00	15,000
12 T7EBT7-SS 12.0	3/4	12.00	3.00	15,000

Assemble 1/2 turn from finger tight.

* Same Assembled Lengths as [EBMP7](#) with two (2) [MP7PCs](#).

CBMP7 MPI™ to Male NPT Elbow

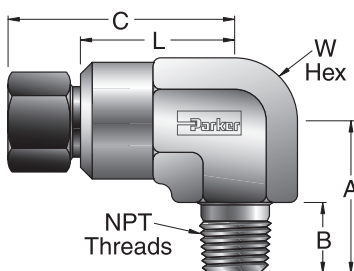

Parker Part No.	Inches							Working Pressure (PSIG)
	MPI™ Size	NPT Thread	A	B	C	L	W Hex	
4-4 CBMP7	1/4	1/4 - 18	1.13	.57	1.53	1.03	3/4	15,000
4-6 CBMP7	1/4	3/8 - 18	1.13	.57	1.56	1.06	3/4	12,000
4-8 CBMP7	1/4	1/2 - 14	1.41	.76	1.64	1.14	3/4	10,000
6-4 CBMP7	3/8	1/4 - 18	1.23	.57	1.86	1.24	7/8	12,500
6-6 CBMP7	3/8	3/8 - 18	1.23	.57	1.86	1.24	7/8	12,000
6-8 CBMP7	3/8	1/2 - 14	1.41	.76	1.92	1.30	7/8	10,000

MPI™ FITTINGS

JBMP7 MPI™ Union Tee

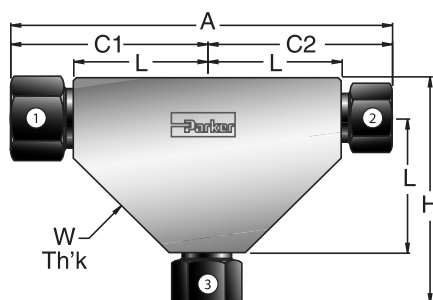

Parker Part No.	Inches									Working Pressure (PSIG)
	MPI™ Size #1	MPI™ Size #2	MPI™ Size #3	A	C1	C2	H	L	W Th'k	
4-4-4 JBMP7	1/4	1/4	1/4	3.06	1.53	1.53	1.88	1.03	5/8	15,000
6-6-6 JBMP7	3/8	3/8	3/8	3.72	1.86	1.86	2.25	1.24	3/4	15,000
8-8-8 JBMP7	1/2	1/2	1/2	4.45	2.22	2.22	2.81	1.54	1	15,000
9-9-9 JBMP7	9/16	9/16	9/16	4.57	2.29	2.29	2.88	1.54	1	15,000
12-12-12 JBMP7	3/4	3/4	3/4	5.64	2.82	2.82	3.51	1.94	1 3/8	15,000
16-16-16 JBMP7	1	1	1	7.27	3.63	3.63	4.51	2.50	1 3/4	12,500
4-4-6 JBMP7	1/4	1/4	3/8	3.47	1.74	1.74	2.25	1.24	3/4	15,000
6-6-4 JBMP7	3/8	3/8	1/4	3.72	1.86	1.86	2.13	1.24	3/4	15,000
6-4-4 JBMP7	3/8	1/4	1/4	3.60	1.86	1.74	2.13	1.24	3/4	15,000
6-6-8 JBMP7	3/8	3/8	1/2	4.32	2.16	2.16	2.81	1.54	1	15,000
6-6-9 JBMP7	3/8	3/8	9/16	4.45	2.16	2.29	2.88	1.54	1	15,000
8-8-6 JBMP7	1/2	1/2	3/8	4.45	2.22	2.22	2.75	1.54	1	15,000
8-6-6 JBMP7	1/2	3/8	3/8	4.38	2.22	2.16	2.75	1.54	1	15,000
9-9-4 JBMP7	9/16	9/16	1/4	4.57	2.29	2.29	2.63	1.54	1	15,000
9-9-6 JBMP7	9/16	9/16	3/8	4.57	2.29	2.29	2.75	1.54	1	15,000
9-6-4 JBMP7	9/16	3/8	1/4	4.45	2.29	2.16	2.63	1.54	1	15,000
9-6-6 JBMP7	9/16	3/8	3/8	4.45	2.29	2.16	2.75	1.54	1	15,000
12-12-9 JBMP7	3/4	3/4	9/16	5.64	2.82	2.82	3.38	1.94	1 3/8	15,000
16-16-9 JBMP7	1	1	9/16	7.27	3.63	3.63	4.13	2.50	1 3/4	12,500
16-16-12 JBMP7	1	1	3/4	7.27	3.63	3.63	4.26	2.50	1 3/4	12,500

X44HBMP7 X44 Male by MPI™ Connector

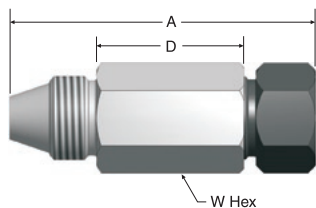

Parker Part No.	Inches					Working Pressure (PSIG)
	X44 Adapter	MPI™ Size	A	D	W Hex	
9-9 X44HBMP7	9/16	9/16	3.20	1.54	1-1/16	15,000
9-12 X44HBMP7	9/16	3/4	3.98	2.19	1-3/8	15,000
12-9 X44HBMP7	3/4	9/16	3.15	1.35	1-1/4	15,000
12-12 X44HBMP7	3/4	3/4	3.89	1.96	1-3/8	15,000

X44HT7 X44 Male by MPI™ Tube Stub

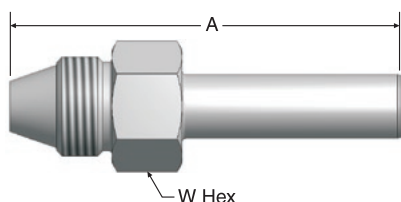

Parker Part No.	Inches				Working Pressure (PSIG)
	X44 Adapter	MPI™ Tube	A	W Hex	
9-9 X44HT7	9/16	9/16	3.60	1	15,000
9-12 X44HT7	9/16	3/4	3.95	1	15,000
12-9 X44HT7	3/4	9/16	3.74	1-1/4	15,000
12-12 X44HT7	3/4	3/4	4.09	1-1/4	15,000

M40HX44 Type “M” Male by X44 Male

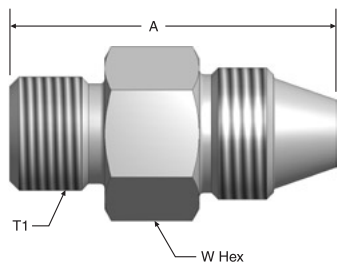

Parker Part No.	Inches					Working Pressure (PSIG)
	Type “M” Adapter	X44 Adapter	T1 Thread	A	W Hex	
6-9 M40HX44	3/8	9/16	9/16-18 UNF	1.79	1	15,000
6-12 M40HX44	3/8	3/4	9/16-18 UNF	2.06	1-1/4	15,000
8-9 M40HX44	1/2	9/16	3/4-16 UNF	1.99	1	15,000
8-12 M40HX44	1/2	3/4	3/4-16 UNF	2.18	1-1/4	15,000
11-9 M40HX44	11/16	9/16	1-12 UNF	2.04	1	15,000
11-12 M40HX44	11/16	3/4	1-12 UNF	2.18	1-1/4	15,000

X44 Adapter Assembly

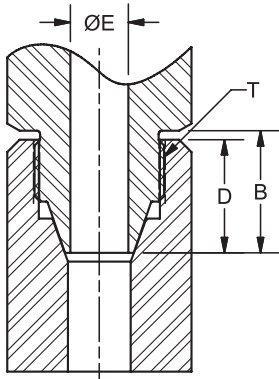

Size	T Thread	B	D Insertion Depth	ØE	Assembly Torque
9	7/8-14	0.91	0.84	0.38	80 ft-lb
12	1-1/8-12	1.05	0.98	0.50	165 ft-lb

MPI™ FITTINGS

RBMP7 MPI™ to Male Run NPT Tee

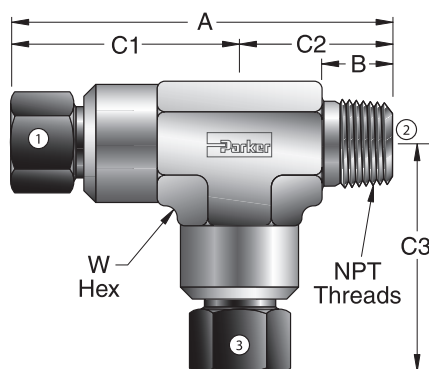

Parker Part No.	Inches									Working Pressure (PSIG)
	MPI™ Size #1	NPT Thread #2	MPI™ Size #3	A	C1	C2	C3	B	W Hex	
4-4-4 RBMP7	1/4	1/4 - 18	1/4	2.76	1.63	1.13	1.63	.57	3/4	15,000
4-4-6 RBMP7	1/4	1/4 - 18	3/8	2.85	1.63	1.23	1.86	.57	7/8	12,500
4-6-4 RBMP7	1/4	3/8 - 18	1/4	2.76	1.63	1.13	1.63	.57	3/4	12,000
4-6-6 RBMP7	1/4	3/8 - 18	3/8	2.85	1.63	1.23	1.86	.57	7/8	12,000
6-4-4 RBMP7	3/8	1/4 - 18	1/4	3.09	1.86	1.23	1.63	.57	7/8	12,500
6-4-6 RBMP7	3/8	1/4 - 18	3/8	3.09	1.86	1.23	1.86	.57	7/8	12,500
6-6-4 RBMP7	3/8	3/8 - 18	1/4	3.09	1.86	1.23	1.63	.57	7/8	12,000
6-6-6 RBMP7	3/8	3/8 - 18	3/8	3.09	1.86	1.23	1.86	.57	7/8	12,000

SBMP7 MPI™ to Male Branch NPT Tee

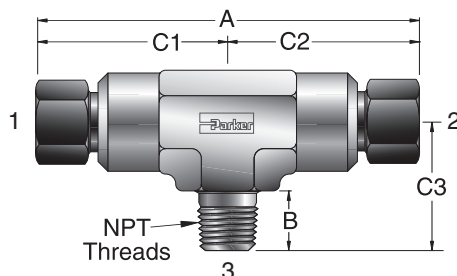

Parker Part No.	Inches									Working Pressure (PSIG)
	MPI™ Size #1	MPI™ Size #2	NPT Thread #3	A	C1	C2	C3	B	W Hex	
4-4-4 SBMP7	1/4	1/4 - 18	1/4	3.25	1.63	1.63	1.13	.57	3/4	15,000
4-4-6 SBMP7	1/4	3/8 - 18	3/8	3.25	1.63	1.63	1.13	.57	3/4	12,000
6-6-4 SBMP7	3/8	1/4 - 18	3/8	3.72	1.86	1.86	1.23	.57	7/8	12,500
6-6-6 SBMP7	3/8	3/8 - 18	3/8	3.72	1.86	1.86	1.23	.57	7/8	12,000

MPI™ Medium Pressure Fittings

OBMP7 MPI™ to NPT Female Branch Tee

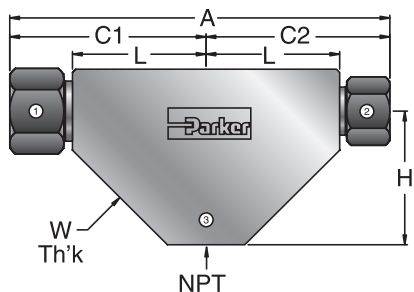

Parker Part No.	Inches									Working Pressure (PSIG)
	MPI™ Size #1	MPI™ Size #2	NPT Thread #3	A	C1	C2	C3	B	W Th'k	
4-4-4 OBMP7	1/4	1/4	1/4-18	3.47	1.74	1.74	1.24	1.24	3/4	15,000
6-6-4 OBMP7	3/8	3/8	1/4-18	3.72	1.86	1.86	1.24	1.24	3/4	15,000
6-6-8 OBMP7	3/8	3/8	1/2-14	3.88	1.94	1.94	1.54	1.31	1 3/8	15,000
8-8-8 OBMP7	1/2	1/2	1/2-14	4.45	2.22	2.22	1.94	1.54	1 3/8	15,000
9-9-8 OBMP7	9/16	9/16	1/2-14	4.57	2.29	2.29	1.94	1.54	1 3/8	15,000
12-12-8 OBMP7	3/4	3/4	1/2-14	5.64	2.82	2.82	1.94	1.94	1 3/8	15,000

KBMP7 MPI™ Union Cross

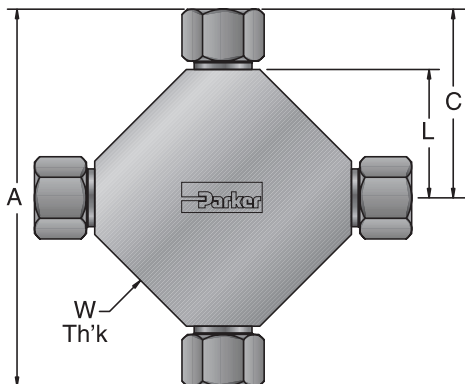

Parker Part No.	MPI™ Size	Inches				Working Pressure (PSIG)
		A	C	L	W Th'k	
4 KBMP7	1/4	3.06	1.53	1.03	5/8	15,000
6 KBMP7	3/8	3.72	1.86	1.24	3/4	15,000
8 KBMP7	1/2	4.45	2.22	1.54	1	15,000
9 KBMP7	9/16	4.57	2.29	1.54	1	15,000
12 KBMP7	3/4	5.64	2.82	1.94	1 3/8	15,000

MPI™ FITTINGS

FNMP7 MPI™ Plug, Assembly

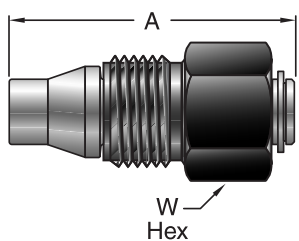

Parker Part No.	Inches			Working Pressure (PSIG)
	MPI™ Size	A	W Hex	
4 FNMP7	1/4	1.41	9/16	15,000
6 FNMP7	3/8	1.65	11/16	15,000
8 FNMP7	1/2	1.94	15/16	15,000
9 FNMP7	9/16	2.00	1	15,000
12 FNMP7	3/4	2.35	1 1/4	15,000
16 FNMP7	1	2.96	1 1/2	12,500

Assemble 1/4 to 1/2 turn from finger tight.

FNM7 MPI™ Plug, Solid

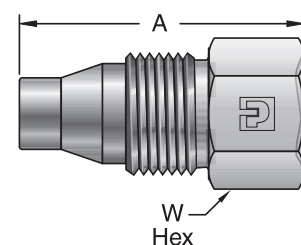

Parker Part No.	Inches			Working Pressure (PSIG)
	MPI™ Size	A	W Hex	
4 FNM7	1/4	1.26	9/16	15,000
6 FNM7	3/8	1.49	11/16	15,000
8 FNM7	1/2	1.76	15/16	15,000
9 FNM7	9/16	1.82	1	15,000
12 FNM7	3/4	2.17	1 1/4	15,000

Assemble 1/4 to 1/2 turn from finger tight and lubricate threads and taper before each remake.

PNBMP7 MPI™ Cap

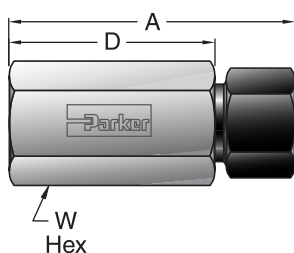

Parker Part No.	Inches				Working Pressure (PSIG)
	MPI™ Size	A	D	W Hex	
4 PNBMP7	1/4	1.69	1.19	5/8	15,000
6 PNBMP7	3/8	2.12	1.49	3/4	15,000
8 PNBMP7	1/2	2.62	1.93	1	15,000
9 PNBMP7	9/16	2.75	2.00	1 1/16	15,000
12 PNBMP7	3/4	3.53	2.64	1 3/8	15,000
16 PNBMP7	1	4.44	3.31	1 3/4	12,500

MPFF MPI™ Front Ferrule

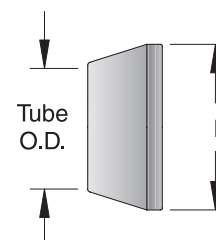

Parker Part No.	Tube O.D.	Ferrule O.D.
4 MPFF	1/4	0.40
6 MPFF	3/8	0.52
8 MPFF	1/2	0.72
9 MPFF	9/16	0.78
12 MPFF	3/4	0.99
16 MPFF	1	1.30

BMP7 MPI™ Nut

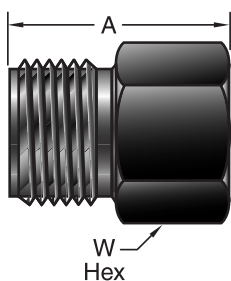

Parker Part No.	MPI™ Size	A	W Hex
4 BMP7	1/4	0.81	9/16
6 BMP7	3/8	0.92	11/16
8 BMP7	1/2	0.97	15/16
9 BMP7	9/16	1.03	1
12 BMP7	3/4	1.34	1 1/4
16 BMP7	1	1.74	1 1/2

MPBF MPI™ Back Ferrule

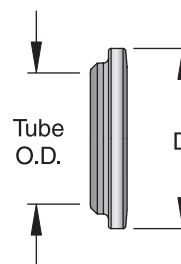

Parker Part No.	Tube O.D.	Ferrule O.D.
4 MPBF	1/4	0.40
6 MPBF	3/8	0.52
8 MPBF	1/2	0.72
9 MPBF	9/16	0.78
12 MPBF	3/4	0.99
16 MPBF	1	1.30

MPI™ FITTINGS

Gaugeability Tools

Gap Gauge

This one handy gauge works for all MPI™ sizes. The end of the gauge checks the fitting gap after make-up. See [page 44](#) for make-up and inspection instructions.



Gap Gauge

Size	Parker Part No.
1/4	4 MPI GAP Gauge
3/8	6 MPI GAP Gauge
1/2	8 MPI GAP Gauge
9/16	9 MPI GAP Gauge
3/4	12 MPI GAP Gauge
1	16 MPI GAP Gauge

Medium Pressure Valves

MPN Series Valves

Parker MPN series valves are designed for multi-turn control of media regulation and shutoff up to 20,000 psi. Additional packing materials are available for application temperatures from -300°F to +800°F. Standard critical service design features, such as the packing below the thread and the non-rotating lower stem ensure longer valve life in gung applications.

Medium Pressure Valve Connection Types

F
Female NPT
To 15,000 PSI



MP7
Parker MPI™
(Medium Pressure
Inverted)
To 15,000 PSI

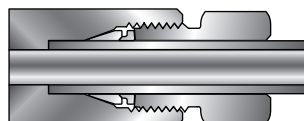

MF
Cone & Thread
(Medium Pressure
Female)
To 20,000 PSI

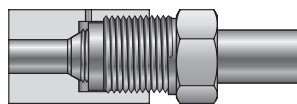

MEDIUM PRESSURE VALVES

Materials of Construction

Item #	Description	Material
1	Soc Set Screw	Steel
2	Handle	Aluminum
3	Upper Stem Assembly	17-4PH
4	Packing Gland	316SS
5	Locking Device	300 SER. SS
6	10-32 X 1/4 Fill HD SCR.	300 SER. SS
7	Stem Pin	304SS
8	Top Packing Washer	416SS
9	Packing	PTFE
10	Bottom Packing Washer	316SS
11	Lower Stem	17-4PH-H900
12	Body	316SS

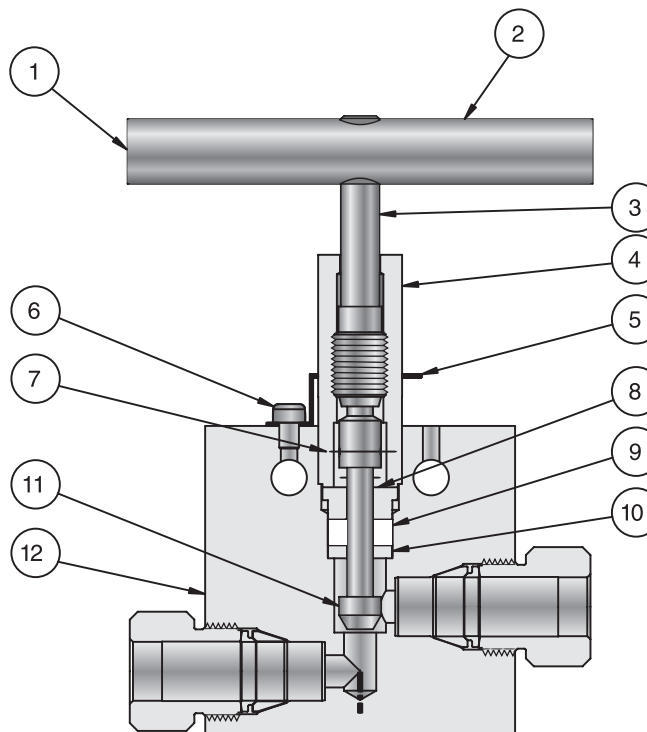

Two Way Inline Valves

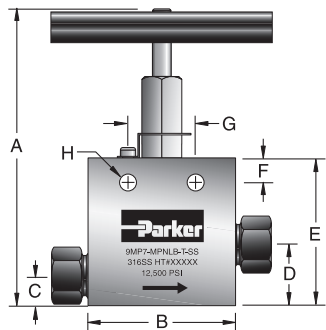

Panel Hole Sizes
Medium Pressure Needle Valve Panel Mount

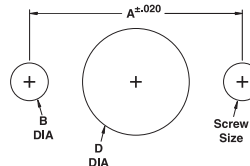

Valve Size	A	B	Screw Size	D
4 & 6	1.25	.219	10 - 32	.75
8 & 9	1.375	.219	10 - 32	1.00
12	1.75	.219	10 - 32	1.19
16	2.50	.219	10 - 32	1.63

Tubing Size	Parker Part No.	PSI	Connection	Inches									
				Orifice	A	B	C	D	E	F	G	H	Th'k
1/4" O.D.	4MP7-MPNLB-T-SS	15,000	1/4" MPI	0.125	4.50	2.50	0.50	0.94	2.13	0.38	1.25	0.22	1.00
3/8" O.D.	6MP7-MPNLB-T-SS	15,000	3/8" MPI	0.203	4.50	2.50	0.50	0.94	2.13	0.38	1.25	0.22	1.00
1/2" O.D.	8MP7-MPNLB-T-SS	15,000	1/2" MPI	0.313	6.26	3.00	0.63	1.25	3.00	0.50	1.38	0.34	1.38
9/16" O.D.	9MP7-MPNLB-T-SS	15,000	9/16" MPI	0.313	6.26	3.00	0.63	1.25	3.00	0.50	1.38	0.34	1.38
3/4" O.D.	12MP7-MPNLB-T-SS	15,000	3/4" MPI	0.438	7.00	4.13	0.75	1.50	3.75	0.63	1.75	0.44	1.75
3/4" O.D.	12MP7-MPNLBH-T-SS	10,000	3/4" MPI	0.516	7.00	4.13	0.75	1.50	3.75	0.63	1.75	0.44	1.75
1" O.D.	16MP7-MPNLB-T-SS	12,500	1" MPI	0.563	8.42	4.13	0.88	1.81	4.63	1.13	2.50	0.56	1.75

Pipe Size	Parker Part No.	PSI	Connection Female NPT	Inches									
				Orifice	A	B	C	D	E	F	G	H	Th'k
1/8" NPT	2F-MPNLB-T-SS	15,000	1/8"	0.203	4.38	2.00	0.38	0.81	2.00	0.38	1.25	0.22	0.75
1/4" NPT	4F-MPNLB-T-SS	15,000	1/4"	0.203	4.38	2.00	0.38	0.81	2.00	0.38	1.25	0.22	0.75
3/8" NPT	6F-MPNLB-T-SS	15,000	3/8"	0.312	6.13	2.50	0.50	1.13	2.88	0.50	1.38	0.34	1.00
1/2" NPT	8F-MPNLB-T-SS	15,000	1/2"	0.312	6.38	2.63	0.75	1.38	3.13	0.50	1.38	0.34	1.50
3/4" NPT	12F-MPNLB-T-SS	10,000	3/4"	0.687	8.50	4.13	0.88	1.81	4.63	1.13	2.50	0.56	1.75
1" NPT	16F-MPNLB-T-SS	10,000	1"	0.687	8.50	4.13	0.88	1.81	4.63	1.13	2.50	0.56	1.75

MEDIUM PRESSURE VALVES

Two Way Angle Valves

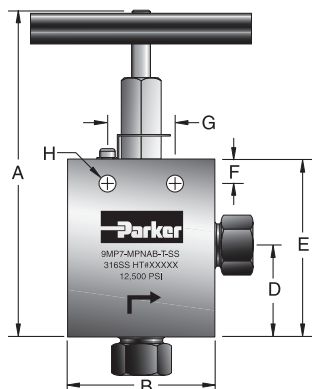

Panel Hole Sizes
Medium Pressure Needle Valve Panel Mount

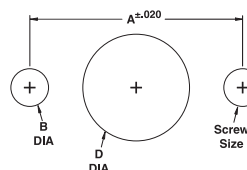

Valve Size	A	B	Screw Size	D
4 & 6	1.25	.219	10 - 32	.75
8 & 9	1.375	.219	10 - 32	1.00
12	1.75	.219	10 - 32	1.19
16	2.50	.219	10 - 32	1.63

MEDIUM PRESSURE VALVES

Tubing	Parker Part No.	PSI	Connection	Inches									
				Orifice	A	B	C	D	E	F	G	H	Th'k
1/4" O.D.	4MP7-MPNAB-T-SS	15,000	1/4" MPI	0.125	5.02	2.50	-	1.38	2.57	0.38	1.25	0.22	1.00
3/8" O.D.	6MP7-MPNAB-T-SS	15,000	3/8" MPI	0.203	5.02	2.50	-	1.38	2.57	0.38	1.25	0.22	1.00
1/2" O.D.	8MP7-MPNAB-T-SS	15,000	1/2" MPI	0.313	6.84	3.00	-	1.83	3.58	0.50	1.38	0.34	1.38
9/16" O.D.	9MP7-MPNAB-T-SS	15,000	9/16" MPI	0.313	6.84	3.00	-	1.83	3.58	0.50	1.38	0.34	1.38
3/4" O.D.	12MP7-MPNAB-T-SS	15,000	3/4" MPI	0.438	7.50	3.00	-	2.00	4.25	0.63	1.75	0.44	1.38
3/4" O.D.	12MP7-MPNABH-T-SS	10,000	3/4" MPI	0.516	7.50	3.00	-	2.00	4.25	0.63	1.75	0.44	1.38
1" O.D.	16MP7-MPNAB-T-SS	12,500	1" MPI	0.563	9.38	4.13	-	2.56	5.44	1.13	2.50	0.56	1.75
1" O.D.	16MP7-MPNABH-T-SS	10,000	1" MPI	0.688	9.38	4.13	-	2.56	5.44	1.13	2.50	0.56	1.75

Pipe Size	Parker Part No.	PSI	Connection Female NPT	Inches									
				Orifice	A	B	C	D	E	F	G	H	Th'k
1/8" NPT	2F-MPNAB-T-SS	15,000	1/8"	0.203	4.81	2.00	-	1.25	2.44	0.38	1.25	0.22	0.75
1/4" NPT	4F-MPNAB-T-SS	15,000	1/4"	0.203	4.81	2.00	-	1.25	2.44	0.38	1.25	0.22	0.75
3/8" NPT	6F-MPNAB-T-SS	15,000	3/8"	0.312	6.50	2.50	-	1.50	3.25	0.50	1.38	0.34	1.00
1/2" NPT	8F-MPNAB-T-SS	15,000	1/2"	0.312	6.50	2.63	-	1.50	3.25	0.50	1.38	0.34	1.50
3/4" NPT	12F-MPNAB-T-SS	10,000	3/4"	0.687	9.00	4.13	-	2.31	5.13	1.13	2.50	0.56	1.75
1" NPT	16F-MPNAB-T-SS	10,000	1"	0.687	9.00	4.13	-	2.31	5.13	1.13	2.50	0.56	1.75

Three Way/Two Pressure Connections

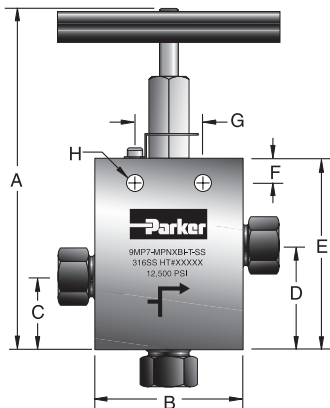

Panel Hole Sizes
Medium Pressure Needle Valve Panel Mount

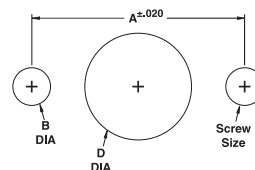

Valve Size	A	B	Screw Size	D
4 & 6	1.25	.219	10 - 32	.75
8 & 9	1.375	.219	10 - 32	1.00
12	1.75	.219	10 - 32	1.19
16	2.50	.219	10 - 32	1.63

Tubing	Parker Part No.	PSI	Connection	Inches									
				Orifice	A	B	C	D	E	F	G	H	Th'k
1/4" O.D.	4MP7-MPNXBI-T-SS	15,000	1/4" MPI	0.125	5.21	2.50	1.21	1.65	2.84	0.38	1.25	0.22	1.00
3/8" O.D.	6MP7-MPNXBI-T-SS	15,000	3/8" MPI	0.203	5.21	2.50	1.21	1.65	2.84	0.38	1.25	0.22	1.00
1/2" O.D.	8MP7-MPNXBI-T-SS	15,000	1/2" MPI	0.313	7.09	3.00	1.50	2.12	3.88	0.50	1.38	0.34	1.38
9/16" O.D.	9MP7-MPNXBI-T-SS	15,000	9/16" MPI	0.313	7.09	3.00	1.50	2.12	3.88	0.50	1.38	0.34	1.38
3/4" O.D.	12MP7-MPNXBI-T-SS	15,000	3/4" MPI	0.438	7.88	3.00	2.63	2.38	4.63	0.63	1.75	0.44	1.38
3/4" O.D.	12MP7-MPNXBIIH-T-SS	10,000	3/4" MPI	0.516	7.88	3.00	2.63	2.38	4.63	0.63	1.75	0.44	1.38
1" O.D.	16MP7-MPNXBI-T-SS	12,500	1" MPI	0.563	9.75	4.13	2.13	3.06	5.88	1.13	2.50	0.56	1.75
1" O.D.	16MP7-MPNXBIIH-T-SS	10,000	1" MPI	0.688	9.75	4.13	2.13	3.06	5.88	1.13	2.50	0.56	1.75

MEDIUM PRESSURE VALVES

Three Way/One Pressure Connection

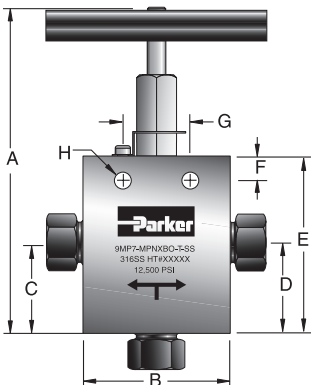

Panel Hole Sizes
Medium Pressure Needle Valve Panel Mount

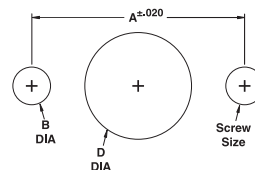

Valve Size	A	B	Screw Size	D
4 & 6	1.25	.219	10 - 32	.75
8 & 9	1.375	.219	10 - 32	1.00
12	1.75	.219	10 - 32	1.19
16	2.50	.219	10 - 32	1.63

Tubing	Parker Part No.	PSI	Connection	Inches									
				Orifice	A	B	C	D	E	F	G	H	Th'k
1/4" O.D.	4MP7-MPNXBO-T-SS	15,000	1/4" MPI	0.125	5.02	2.50	1.38	1.38	2.57	0.38	1.25	0.22	1.00
3/8" O.D.	6MP7-MPNXBO-T-SS	15,000	3/8" MPI	0.203	5.02	2.50	1.38	1.38	2.57	0.38	1.25	0.22	1.00
1/2" O.D.	8MP7-MPNXBO-T-SS	15,000	1/2" MPI	0.313	6.84	3.00	1.88	1.88	3.63	0.50	1.38	0.34	1.38
9/16" O.D.	9MP7-MPNXBO-T-SS	15,000	9/16" MPI	0.313	6.84	3.00	1.88	1.88	3.63	0.50	1.38	0.34	1.38
3/4" O.D.	12MP7-MPNXBO-T-SS	15,000	3/4" MPI	0.438	7.50	3.00	2.00	2.00	4.25	0.63	1.75	0.44	1.38
3/4" O.D.	12MP7-MPNXBOH-T-SS	10,000	3/4" MPI	0.516	7.50	3.00	2.00	2.00	4.25	0.63	1.75	0.44	1.38
1" O.D.	16MP7-MPNXBO-T-SS	12,500	1" MPI	0.563	9.38	4.13	2.63	2.63	5.44	1.13	2.50	0.56	1.75
1" O.D.	16MP7-MPNXBOH-T-SS	10,000	1" MPI	0.688	9.38	4.13	2.63	2.63	5.44	1.13	2.50	0.56	1.75



Three Way/Two Stem Connection

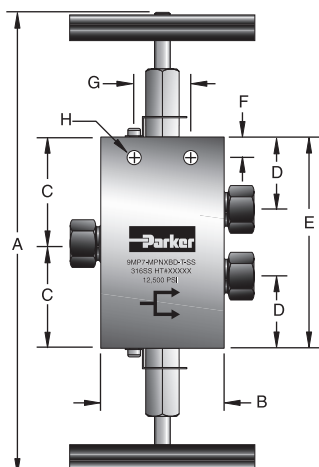

Panel Hole Sizes
Medium Pressure Needle Valve Panel Mount

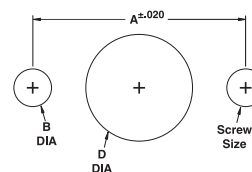

Valve Size	A	B	Screw Size	D
4 & 6	1.25	.219	10 - 32	.75
8 & 9	1.375	.219	10 - 32	1.00
12	1.75	.219	10 - 32	1.19
16	2.50	.219	10 - 32	1.63

MEDIUM PRESSURE VALVES

Tubing	Parker Part No.	PSI	Connection	Inches									
				Orifice	A	B	C	D	E	F	G	H	Th'k
1/4" O.D.	4MP7-MPNXBD-T-SS	15,000	1/4" MPI	0.125	5.75	2.50	1.70	1.19	3.38	0.38	1.25	0.22	1.00
3/8" O.D.	6MP7-MPNXBD-T-SS	15,000	3/8" MPI	0.203	5.75	2.50	1.70	1.19	3.38	0.38	1.25	0.22	1.00
1/2" O.D.	8MP7-MPNXBD-T-SS	15,000	1/2" MPI	0.313	8.38	3.00	2.56	1.75	5.13	0.50	1.38	0.34	1.38
9/16" O.D.	9MP7-MPNXBD-T-SS	15,000	9/16" MPI	0.313	8.38	3.00	2.56	1.75	5.13	0.50	1.38	0.34	1.38
3/4" O.D.	12MP7-MPNXBD-T-SS	15,000	3/4" MPI	0.438	9.75	3.00	3.25	2.25	6.50	0.63	1.75	0.44	1.38
3/4" O.D.	12MP7-MPNXBDH-T-SS	10,000	3/4" MPI	0.516	9.75	3.00	3.25	2.25	6.50	0.63	1.75	0.44	1.38
1" O.D.	16MP7-MPNXBD-T-SS	12,500	1" MPI	0.563	12.19	4.13	4.13	2.81	8.25	1.13	2.50	0.56	1.75
1" O.D.	16MP7-MPNXBDH-T-SS	10,000	1" MPI	0.688	12.19	4.13	4.13	2.81	8.25	1.13	2.50	0.56	1.75

Two Way Angle Valves (Replaceable Seat)

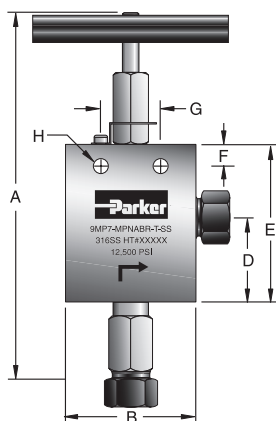

Panel Hole Sizes
Medium Pressure Needle Valve Panel Mount

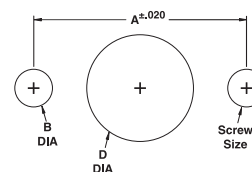

Valve Size	A	B	Screw Size	D
4 & 6	1.25	.219	10 - 32	.75
8 & 9	1.375	.219	10 - 32	1.00
12	1.75	.219	10 - 32	1.19
16	2.50	.219	10 - 32	1.63

Tubing	Parker Part No.	PSI	Connection	Inches									
				Orifice	A	B	C	D	E	F	G	H	Th'k
1/4" O.D.	4MP7-MPNABR-T-SS	15,000	1/4" MPI	0.125	5.87	2.50	-	1.38	2.57	0.38	1.25	0.22	1.00
3/8" O.D.	6MP7-MPNABR-T-SS	15,000	3/8" MPI	0.203	5.87	2.50	-	1.38	2.57	0.38	1.25	0.22	1.00
1/2" O.D.	8MP7-MPNABR-T-SS	15,000	1/2" MPI	0.313	8.25	3.00	-	2.00	3.63	0.50	1.38	0.34	1.38
9/16" O.D.	9MP7-MPNABR-T-SS	15,000	9/16" MPI	0.313	8.25	3.00	-	2.00	3.63	0.50	1.38	0.34	1.38
3/4" O.D.	12MP7-MPNABR-T-SS	15,000	3/4" MPI	0.438	8.88	3.00	-	2.00	4.25	0.63	1.75	0.44	1.38
3/4" O.D.	12MP7-MPNABRH-T-SS	10,000	3/4" MPI	0.516	8.88	3.00	-	2.00	4.25	0.63	1.75	0.44	1.38
1" O.D.	16MP7-MPNABR-T-SS	12,500	1" MPI	0.563	11.13	4.13	-	2.56	5.44	1.13	2.50	0.56	1.75
1" O.D.	16MP7-MPNABRH-T-SS	10,000	1" MPI	0.688	11.13	4.13	-	2.56	5.44	1.13	2.50	0.56	1.75

How to Order MPN Series Valves

The correct part number is easily derived from the following example and ordering chart. The nine product characteristics required are coded as shown in the chart.

The following example describes an MPN Series needle valve with 1/4" MPI connections, 2 way angle flow path, blunt stem, PTFE packing, stainless steel body and the option for over critical service.

Example: 4MP7-MPNAB-T-SS-OC

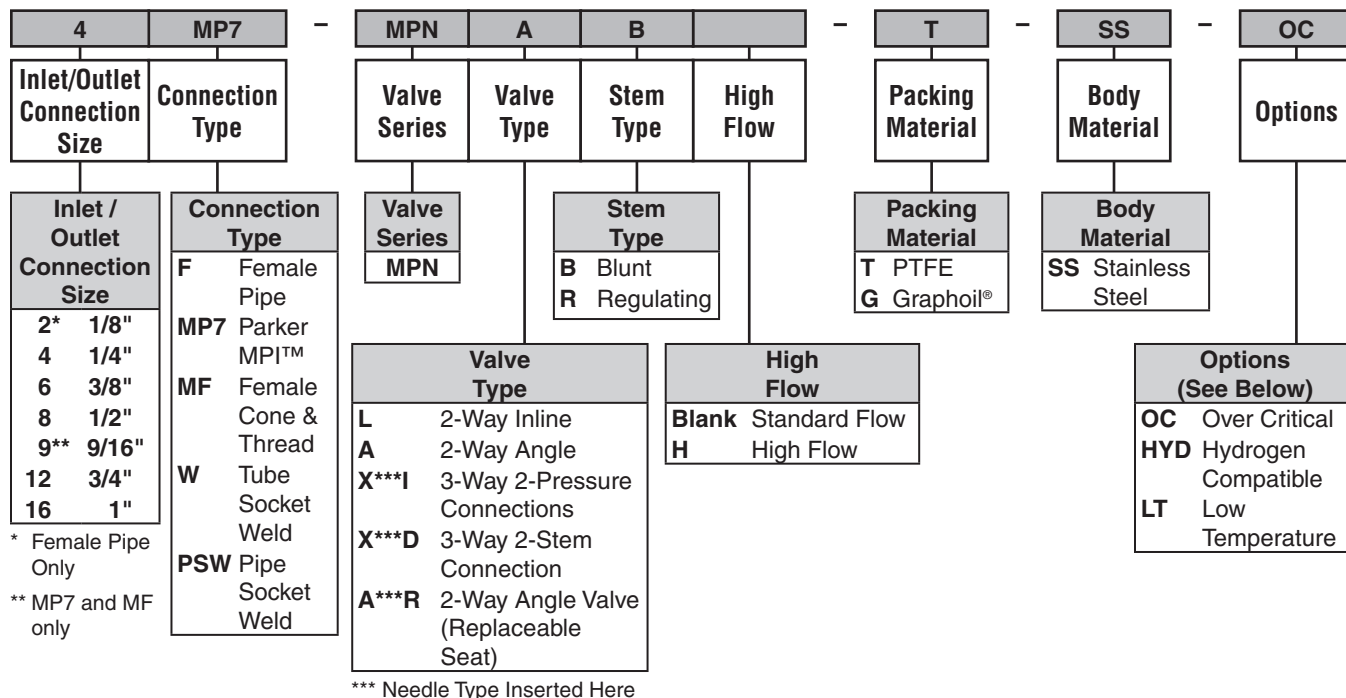

MEDIUM PRESSURE VALVES

How to Order Options

Over Critical – add the suffix **-OC** to the end of the part number to specify over critical service.

Hydrogen Service – add the suffix **-HYD** to the end of the part number for a valve suitable for hydrogen service.

Low Temperature – add the suffix **-LT** to the end of the part number for low temperature service.

Grafoil® is a registered trademark of GrafTech International Holdings, Inc.



Over Critical Valves

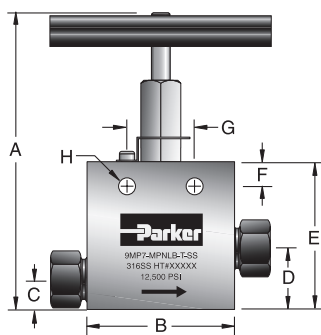

Size	Parker Part No.	PSI	Connection	Orifice	A	B	C	D	E	F	G	H	Th'k
1/4" O.D.	4MP7-MPNLB-G-SS-OC	10,000	4MP7	0.125	4.50	2.50	0.50	0.94	2.13	0.38	1.25	0.22	0.75
3/8" O.D.	6MP7-MPNLB-G-SS-OC	10,000	6MP7	0.203	4.50	2.50	0.50	0.94	2.13	0.38	1.25	0.22	0.75
1/2" O.D.	8MP7-MPNLB-G-SS-OC	10,000	8MP7	0.313	6.26	3.00	0.63	1.25	3.00	0.50	1.38	0.34	1.00
9/16" O.D.	9MP7-MPNLB-G-SS-OC	10,000	9MP7	0.313	6.26	3.00	0.63	1.25	3.00	0.50	1.38	0.34	1.00
3/4" O.D.	12MP7-MPNLB-G-SS-OC	10,000	12MP7	0.438	7.00	3.00	0.75	1.50	3.75	0.63	1.75	0.44	1.38
1" O.D.	16MP7-MPNLB-G-SS-OC	10,000	16MP7	0.563	8.42	4.13	0.88	1.81	4.63	1.13	2.5	0.56	1.75
1/8" NPT	2F-MPNLB-G-SS-OC	10,000	1/8" NPTF	0.203	4.38	2.00	0.38	0.81	2.00	0.38	1.25	0.22	0.75
1/4" NPT	4F-MPNLB-G-SS-OC	10,000	1/4" NPTF	0.203	4.38	2.00	0.38	0.81	2.00	0.38	1.25	0.22	0.75
3/8" NPT	6F-MPNLB-G-SS-OC	10,000	3/8" NPTF	0.312	6.13	2.5	0.50	1.13	2.88	0.50	1.38	0.34	1.00
1/2" NPT	8F-MPNLB-G-SS-OC	10,000	1/2" NPTF	0.312	6.38	2.63	0.75	1.38	3.13	0.50	1.38	0.34	1.50
3/4" NPT	12F-MPNLB-G-SS-OC	10,000	3/4" NPTF	0.687	8.50	4.13	0.88	1.81	4.63	1.13	2.5	0.56	1.75
1" NPT	16F-MPNLB-G-SS-OC	10,000	1" NPTF	0.687	8.50	4.13	0.88	1.81	4.63	1.13	2.5	0.56	1.75

MEDIUM PRESSURE VALVES

Pressure vs. Temperature Chart

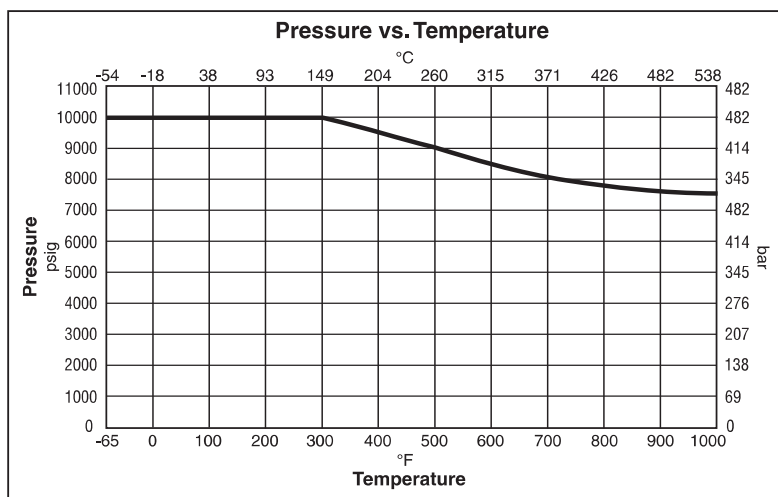

Materials of Construction

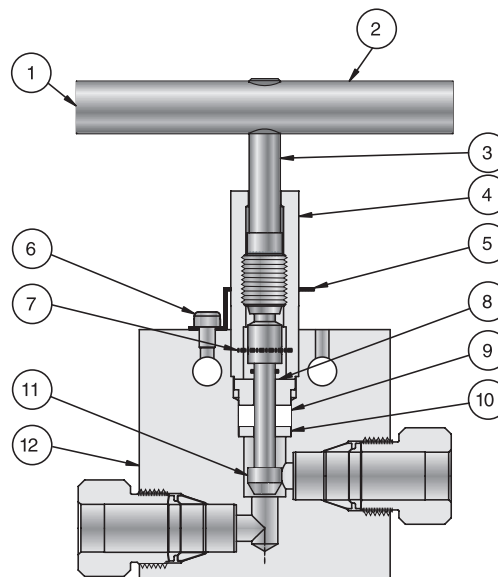

Item #	Description	Material
1	Set Screw	316SS
2	Handle	303SS
3	Upper Stem Assembly	416SS
4	Packing Gland	316SS
5	Locking Device	304SS
6	Lock Screw	304SS
7	Stem Pin	304SS
8	Top Packing Washer	416SS
9	Packing	Grafoil®
10	Bottom Pack Washer	316SS
11	Lower Stem	316SS
12	Body	316SS

Grafoil® is a registered trademark of GrafTech International Holdings, Inc.



Bleed Valve

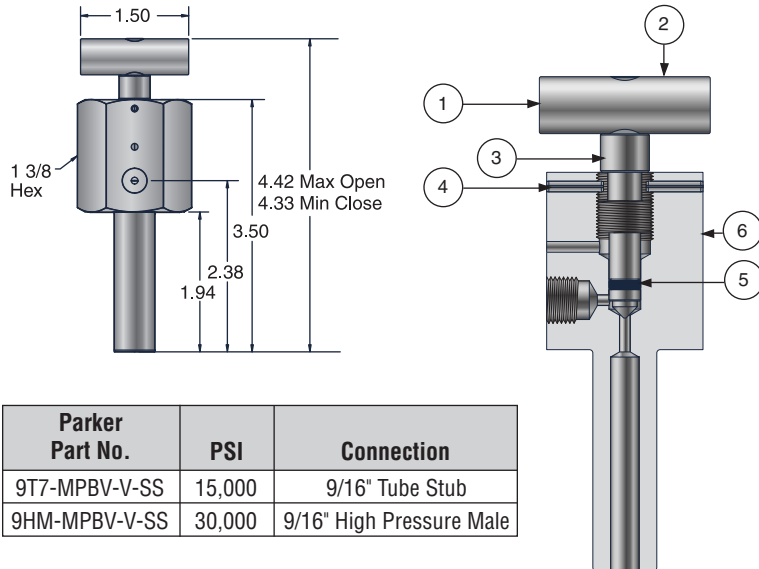

Parker Part No.	PSI	Connection
9T7-MPBV-V-SS	15,000	9/16" Tube Stub
9HM-MPBV-V-SS	30,000	9/16" High Pressure Male

Materials of Construction

Item #	Qty	Description	Material
1	1	Soc Set Screw	300 Ser. SS
2	1	Handle	Aluminum
3	1	Stem	17-4PH-H900
4	2	Rolling Pin	420SS
5	1	O-Ring	Fluorocarbon Rubber*
6	1	Body	316SS

*Optional Seal Materials	
KZ	Highly Fluorinated Fluorocarbon Rubber
BN	Nitrile Rubber
EPR	Ethylene Propylene Rubber

Example: 9T7-MPBV-KZ-SS

MEDIUM PRESSURE VALVES

Gauge Valve

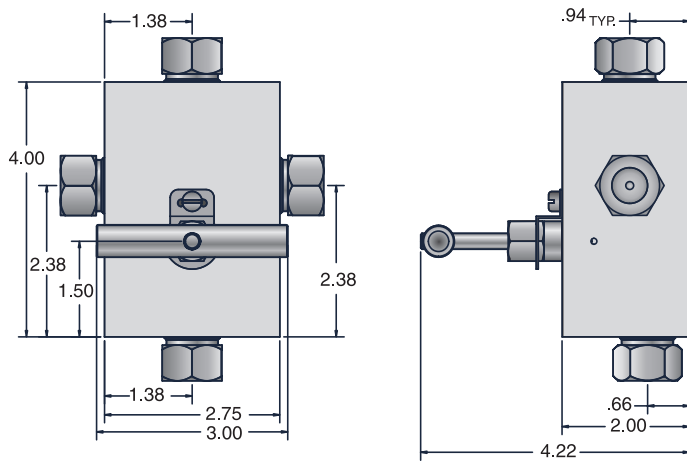

Parker Part No.	PSI	Connection
9MP7-MPGV-V-SS	15,000	9/16" MPI™
9HF-MPGV-V-SS	30,000	9/16" High Pressure Female

Materials of Construction

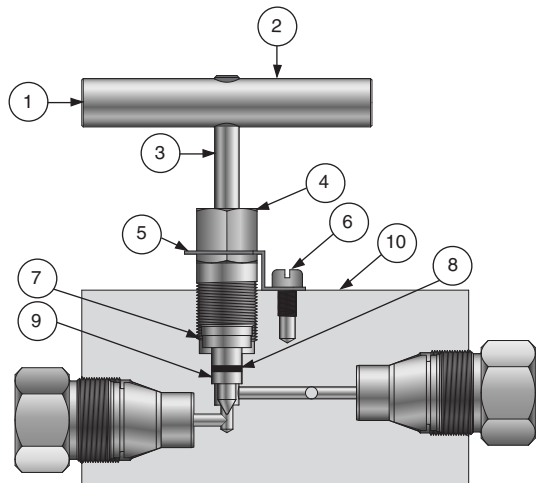

Item #	Qty	Description	Material
1	1	Soc Set Screw	Steel
2	1	Handle	Aluminum
3	1	Stem Assembly	17-4PH
4	1	Packing Gland	316SS
5	1	Locking Device	300 Ser. SS
6	1	10-32 x 1/4 Fill Hd Scr.	300 Ser. SS
7	1	Top Packing Washer	416SS
8	1	Packing	Fluorocarbon Rubber
9	1	Bottom Packing Washer	316SS
10	1	Body	316SS

MPB Series Valves

Parker MPB series manually, pneumatically and electrically actuated two-way and three-way ball valves are designed for 1/4 and 1/2 turn media shutoff or switching applications up to 20,000 psi. Our trunion style ball design and spring loaded seats make the MPB series ideal for severe service applications. The end connector design enables a variety of end connections and combinations for specific customer applications.

Two Way Ball Valves

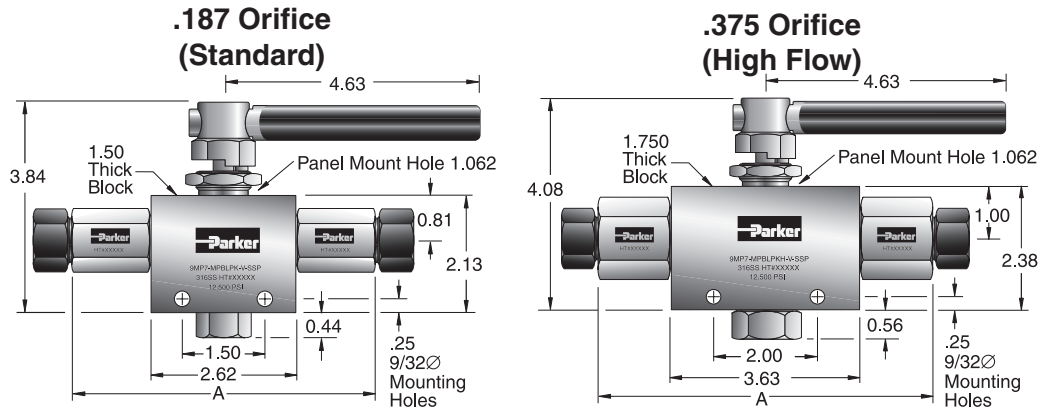

Tubing	Parker Part No.	PSI	Connection	Inches			
				Orifice	Minimum Orifice	C _v	A
Standard							
1/8" O.D.	2F-MPBLPK-V-SSP	15,000	1/8" NPT	0.187	0.187	1.45	4.63
1/4" O.D.	4F-MPBLPK-V-SSP	15,000	1/4" NPT	0.187	0.187	1.45	4.63
1/4" O.D.	4MP7-MPBLPK-V-SSP	15,000	1/4" MPI	0.187	0.125	0.45	5.00
3/8" O.D.	6F-MPBLPK-V-SSP	15,000	3/8" NPT	0.187	0.187	1.45	4.65
3/8" O.D.	6MP7-MPBLPK-V-SSP	15,000	3/8" MPI	0.187	0.187	1.45	5.00
1/2" O.D.	8MP7-MPBLPK-V-SSP	15,000	1/2" MPI	0.187	0.187	1.45	5.50
9/16" O.D.	9MP7-MPBLPK-V-SSP	15,000	9/16" MPI	0.187	0.187	1.45	5.50
High Flow (H)							
1/2" O.D.	8F-MPBLPKH-V-SSP	15,000	1/2" NPT	0.375	0.375	6.08	5.63
1/2" O.D.	8MP7-MPBLPKH-V-SSP	15,000	1/2" MPI	0.375	0.359	5.82	6.44
9/16" O.D.	9MP7-MPBLPKH-V-SSP	15,000	9/16" MPI	0.375	0.359	5.82	6.44
3/4" O.D.	12MP7-MPBLPKH-V-SSP	15,000	3/4" MPI	0.375	0.375	6.08	6.67
1" O.D.	16MP7-MPBLPKH-V-SSP	12,500	1" MPI	0.375	0.375	6.08	7.45
Ultra High Flow (UH)							
3/4" O.D.	12MP7-MPBLPKUH-V-SSP	10,000	3/4" MPI	0.500	0.469	7.60	6.86
1" O.D.	16MP7-MPBLPKUH-V-SSP	10,000	1" MPI	0.500	0.500	8.80	8.48

.500 Orifice Two-Way (UltraHigh Flow)

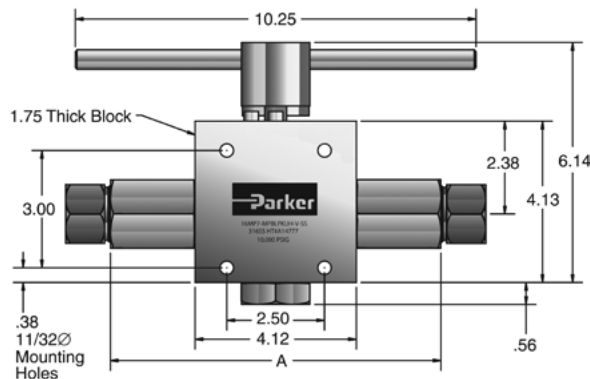

Three Way Ball Valves

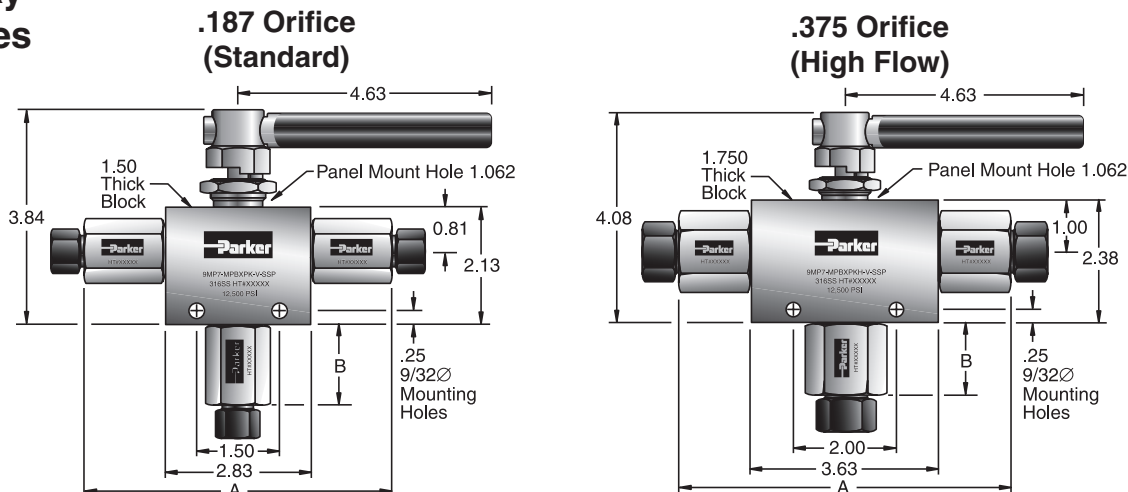

Tubing	Diverter 3-Way 90°	SSelector 3-Way 180°	PSI	Connection	Inches				
					Orifice	Minimum Orifice	C _v	A	B
Standard									
1/8" O.D.	2F-MPBXPKD-V-SSP	2F-MPBXPK-V-SSP	15,000	1/8" NPT	0.187	0.187	0.71	4.63	0.50
1/4" O.D.	4F-MPBXPKD-V-SSP	4F-MPBXPK-V-SSP	15,000	1/4" NPT	0.187	0.187	0.71	4.63	1.06
1/4" O.D.	4MP7-MPBXPKD-V-SSP	4MP7-MPBXPK-V-SSP	15,000	1/4" MPI	0.187	0.125	0.18	5.00	1.18
3/8" O.D.	6F-MPBXPKD-V-SSP	6F-MPBXPK-V-SSP	15,000	3/8" NPT	0.187	0.187	0.71	4.65	1.06
3/8" O.D.	6MP7-MPBXPKD-V-SSP	6MP7-MPBXPK-V-SSP	15,000	3/8" MPI	0.187	0.187	0.71	5.00	1.18
1/2" O.D.	8MP7-MPBXPKD-V-SSP	8MP7-MPBXPK-V-SSP	15,000	1/2" MPI	0.187	0.187	0.71	5.50	1.44
9/16" O.D.	9MP7-MPBXPKD-V-SSP	9MP7-MPBXPK-V-SSP	15,000	9/16" MPI	0.187	0.187	0.71	5.50	1.44
High Flow (H)									
1/2" O.D.	8F-MPBXPKDH-V-SSP	8F-MPBXPKH-V-SSP	15,000	1/2" NPT	0.375	0.375	2.40	5.63	1.06
1/2" O.D.	8MP7-MPBXPKDH-V-SSP	8MP7-MPBXPKH-V-SSP	15,000	1/2" MPI	0.375	0.359	2.30	6.44	1.37
9/16" O.D.	9MP7-MPBXPKDH-V-SSP	9MP7-MPBXPKH-V-SSP	15,000	9/16" MPI	0.375	0.359	2.30	6.44	1.37
3/4" O.D.	12MP7-MPBXPKDH-V-SSP	12MP7-MPBXPKH-V-SSP	15,000	3/4" MPI	0.375	0.375	2.40	6.67	1.18
1" O.D.	16MP7-MPBXPKDH-V-SSP	16MP7-MPBXPKH-V-SSP	15,000	1" MPI	0.375	0.375	2.40	7.45	1.99
Ultra High Flow (UH)									
3/4" O.D.	12MP7-MPBXPKDUH-V-SSP	12MP7-MPBXPKUH-V-SSP	10,000	3/4" MPI	0.500	0.469	3.20	6.86	1.37
1" O.D.	16MP7-MPBXPKDUH-V-SSP	16MP7-MPBXPKUH-V-SSP	10,000	1" MPI	0.500	0.500	3.80	8.48	2.18

Locking Devices – Add suffix “LD” to the end of the part number.
 Example: 9MP7-MPBLPKH-V-SS-LD

.500 Orifice Three-Way

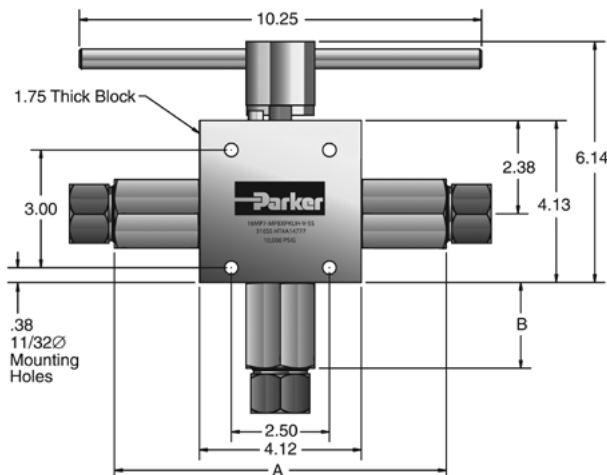

MEDIUM PRESSURE VALVES

Materials of Construction

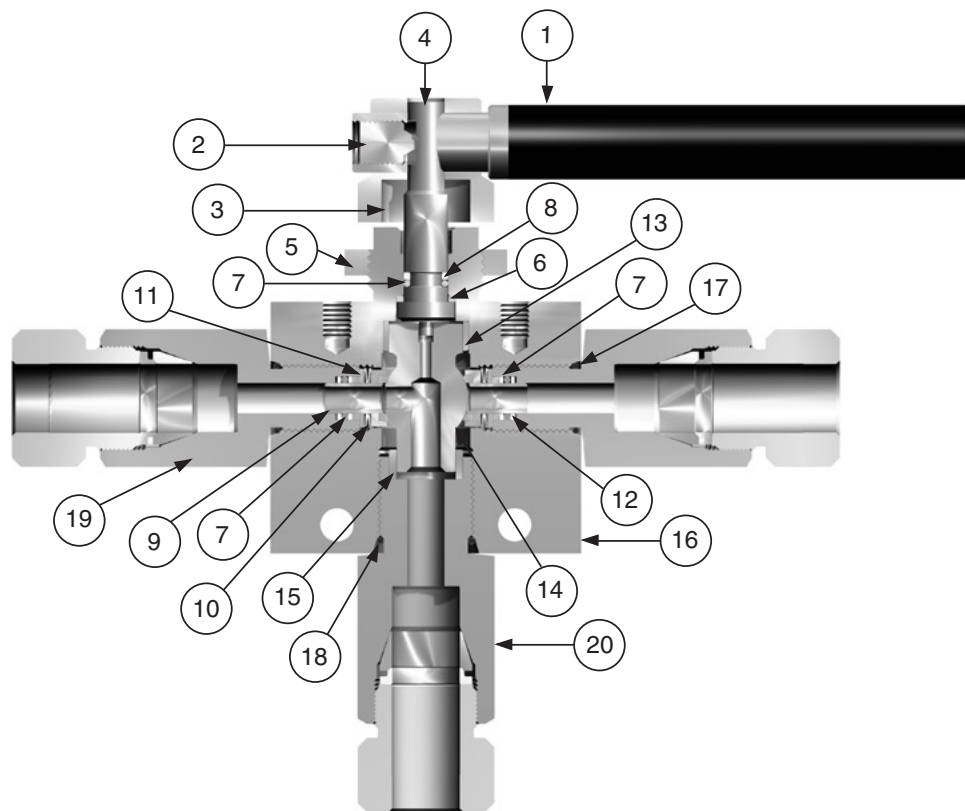

Item #	Description	Material
1	Handle	300 SER. SS
2	Set Screw	17-4PH-H900
3	Stop Collar, 180 Degree	300 SER. SS
4	Stem	17-4PH-H900
5	Panel Nut	300 SER. SS
6	Bearing Washer	Peek/30% Glass
7	O-ring	Fluorocarbon Rubber
8	Back Up Ring	PTFE
9	Ball Seat Assembly	316SS/Arlon
10	Belleville Washer	302SS
11	Packing Washer	316SS
12	Back Up Washer	PTFE
13	Body Bushing	Ampco 45
14	Trunion, 180 Degree	316SS
15	Bottom Bushing	Ampco 45
16	Body	316SS
17	O-ring	Fluorocarbon Rubber
18	O-ring	Fluorocarbon Rubber
19	Seat Gland	316SS
20	Bottom Gland	316SS

MEDIUM PRESSURE VALVES

How to Order MPB Series Valves

The correct part number is easily derived from the following example and ordering chart. The nine product characteristics required are coded as shown in the chart.

The following example describes an MPB Series, three-way diverter ball valve with a .375" orifice, fluorocarbon rubber seals, 1/4" MPI medium pressure inverted connections on all ports and the optional lock out device.

Example:

4MP7 - MPBXP KDH - V - SSP - LD

Inlet/Outlet Connection Size	Connection Type	Valve Series	Valve Type	Seat Material	Three-Way Valve Type	Orifice Size	Seal Material	Body Material	Options																																																																	
<table border="1" style="width: 100%; border-collapse: collapse;"> <tr><th colspan="2">Inlet / Outlet Connection Size</th></tr> <tr><td>2*</td><td>1/8"</td></tr> <tr><td>4</td><td>1/4"</td></tr> <tr><td>6</td><td>3/8"</td></tr> <tr><td>8</td><td>1/2"</td></tr> <tr><td>9**</td><td>9/16"</td></tr> <tr><td>12</td><td>3/4"</td></tr> <tr><td>16</td><td>1"</td></tr> </table>	Inlet / Outlet Connection Size		2*	1/8"	4	1/4"	6	3/8"	8	1/2"	9**	9/16"	12	3/4"	16	1"	<table border="1" style="width: 100%; border-collapse: collapse;"> <tr><th colspan="2">Connection Type</th></tr> <tr><td>F</td><td>Female Pipe</td></tr> <tr><td>MP7</td><td>Parker MPI™</td></tr> <tr><td>MF</td><td>Female Cone & Thread</td></tr> </table>	Connection Type		F	Female Pipe	MP7	Parker MPI™	MF	Female Cone & Thread	<table border="1" style="width: 100%; border-collapse: collapse;"> <tr><th>Valve Series</th></tr> <tr><td>MPB</td></tr> </table>	Valve Series	MPB	<table border="1" style="width: 100%; border-collapse: collapse;"> <tr><th>Valve Type</th></tr> <tr><td>L</td><td>2-Way</td></tr> <tr><td>X</td><td>3-Way</td></tr> </table>	Valve Type	L	2-Way	X	3-Way	<table border="1" style="width: 100%; border-collapse: collapse;"> <tr><th>Seat Material</th></tr> <tr><td>PK</td><td>PEEK</td></tr> </table>	Seat Material	PK	PEEK	<table border="1" style="width: 100%; border-collapse: collapse;"> <tr><th>Three-Way Valve Type</th></tr> <tr><td>Blank</td><td>Selector</td></tr> <tr><td>D</td><td>Diverter</td></tr> </table>	Three-Way Valve Type	Blank	Selector	D	Diverter	<table border="1" style="width: 100%; border-collapse: collapse;"> <tr><th>Orifice Size</th></tr> <tr><td>Blank</td><td>.187"</td></tr> <tr><td>H</td><td>.375"</td></tr> <tr><td>UH</td><td>.500"</td></tr> </table>	Orifice Size	Blank	.187"	H	.375"	UH	.500"	<table border="1" style="width: 100%; border-collapse: collapse;"> <tr><th>Packing Material</th></tr> <tr><td>V***</td><td>Fluorocarbon Rubber</td></tr> <tr><td>KZ</td><td>Highly Fluorinated Fluorocarbon Rubber</td></tr> <tr><td>BN</td><td>Nitrile Rubber</td></tr> <tr><td>EPR</td><td>Ethylene Propylene Rubber</td></tr> </table>	Packing Material	V***	Fluorocarbon Rubber	KZ	Highly Fluorinated Fluorocarbon Rubber	BN	Nitrile Rubber	EPR	Ethylene Propylene Rubber	<table border="1" style="width: 100%; border-collapse: collapse;"> <tr><th>Body Material</th></tr> <tr><td>SSP</td><td>Stainless Steel</td></tr> </table>	Body Material	SSP	Stainless Steel	<table border="1" style="width: 100%; border-collapse: collapse;"> <tr><th>Options (See Below)</th></tr> <tr><td>LD</td><td>Lock out Device</td></tr> <tr><td>SRH</td><td>Spring Return Handle</td></tr> <tr><td>ACT</td><td>Actuated</td></tr> </table>	Options (See Below)	LD	Lock out Device	SRH	Spring Return Handle	ACT	Actuated
Inlet / Outlet Connection Size																																																																										
2*	1/8"																																																																									
4	1/4"																																																																									
6	3/8"																																																																									
8	1/2"																																																																									
9**	9/16"																																																																									
12	3/4"																																																																									
16	1"																																																																									
Connection Type																																																																										
F	Female Pipe																																																																									
MP7	Parker MPI™																																																																									
MF	Female Cone & Thread																																																																									
Valve Series																																																																										
MPB																																																																										
Valve Type																																																																										
L	2-Way																																																																									
X	3-Way																																																																									
Seat Material																																																																										
PK	PEEK																																																																									
Three-Way Valve Type																																																																										
Blank	Selector																																																																									
D	Diverter																																																																									
Orifice Size																																																																										
Blank	.187"																																																																									
H	.375"																																																																									
UH	.500"																																																																									
Packing Material																																																																										
V***	Fluorocarbon Rubber																																																																									
KZ	Highly Fluorinated Fluorocarbon Rubber																																																																									
BN	Nitrile Rubber																																																																									
EPR	Ethylene Propylene Rubber																																																																									
Body Material																																																																										
SSP	Stainless Steel																																																																									
Options (See Below)																																																																										
LD	Lock out Device																																																																									
SRH	Spring Return Handle																																																																									
ACT	Actuated																																																																									

* Female Pipe Only
 ** MP7 and MF only
 *** Standard packing material

MEDIUM PRESSURE VALVES

How to Order Options

Lock Out Devices – add the suffix **-LD** to the end of the part number to order factory mounted on the valve.

Actuated – Contact factory for options.

MPF Series Filters

Parker MPF series filters utilize sintered stainless steel filter discs to trap particles from 0.5 to 100 micron sizes. Inline filters help protect valuable equipment in the process line.

Inline Filters

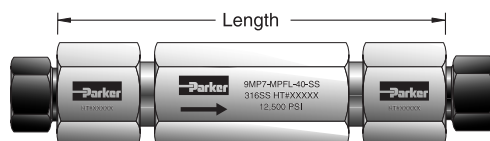

Tubing	Parker Part Number	Pressure psi	Connection	Orifice Inch	Length Inch	Thickness Inch	Filter Micron Size Available					
							0.50	2	5	10	40	100
1/4" O.D.	4MP7-MPFL-*-SS	15,000	1/4" MPI	0.125	5.25	1.38	*	*	*	*	*	*
3/8" O.D.	6MP7-MPFL-*-SS	15,000	3/8" MPI	0.219	5.25	1.38	*	*	*	*	*	*
1/2" O.D.	8MP7-MPFL-*-SS	15,000	1/2" MPI	0.359	5.25	1.38	*	*	*	*	*	*
9/16" O.D.	9MP7-MPFL-*-SS	15,000	9/16" MPI	0.359	5.25	1.38	*	*	*	*	*	*

* Insert Filter Micron size here. This portion of the part number may be one, two or three digits. For example: 4PM7-MPFL-100-SS uses the 100 micron size filter.

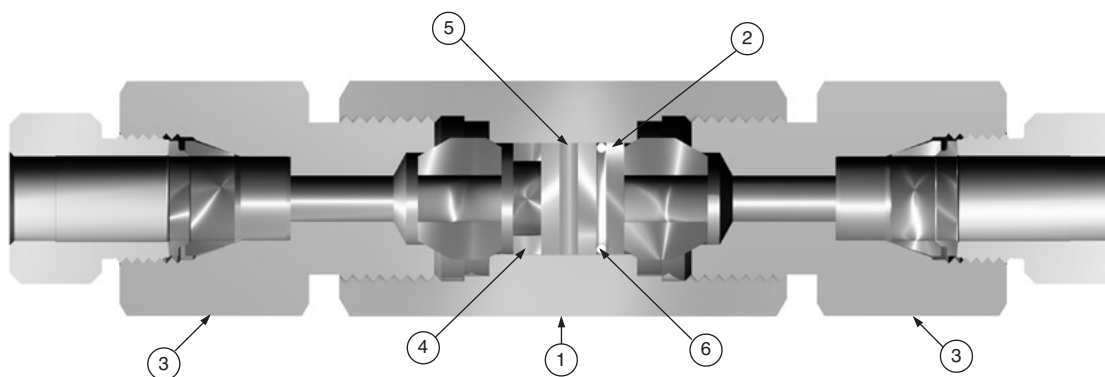

Materials of Construction

Item #	Part	Material
1	Cap	316SS
2	Sealing	316SS
3	Body	316SS
4	Spacer	316SS
5	100 Micron Filter Disc	316SS
6	O-ring	PTFE

MEDIUM PRESSURE VALVES

MPC and MPCB Series Check Valves

Parker MPC and MPCB series check valves are designed for uni-directional flow control of fluids and gases up to 20,000 psi.

Ball Check Valves

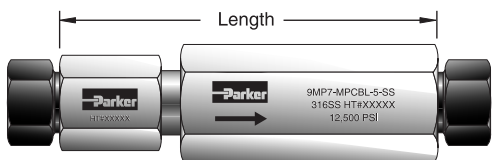

Poppet Check Valves

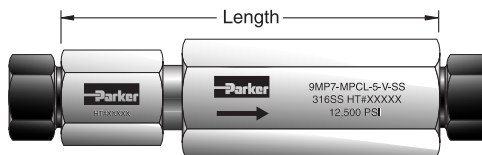

Tubing	Ball Check Valve Part No.	Poppet Check Valve Part No.	psi	Connection	Orifice Inches	Length Inches	Thickness Inches	C _v
1/4" O.D.	4MP7-MPCBL-5-SS	4MP7-MPCL-5-V-SS	15,000	1/4" MPI	0.125	4.16	1.00	0.41
3/8" O.D.	6MP7-MPCBL-5-SS	6MP7-MPCL-5-V-SS	15,000	3/8" MPI	0.219	4.16	1.00	0.62
1/2" O.D.	8MP7-MPCBL-5-SS	8MP7-MPCL-5-V-SS	15,000	1/2" MPI	0.359	5.13	1.38	1.47
9/16" O.D.	9MP7-MPCBL-5-SS	9MP7-MPCL-5-V-SS	15,000	9/16" MPI	0.359	4.50	1.38	1.47
3/4" O.D.	12MP7-MPCBL-5-SS	12MP7-MPCL-5-V-SS	15,000	3/4" MPI	0.438	5.13	1.75	4.01
1" O.D.	16MP7-MPCBL-5-SS	16MP7-MPCL-5-V-SS	12,500	1" MPI	0.563	6.50	2.50	4.78

MEDIUM PRESSURE VALVES

Ball Check Valves

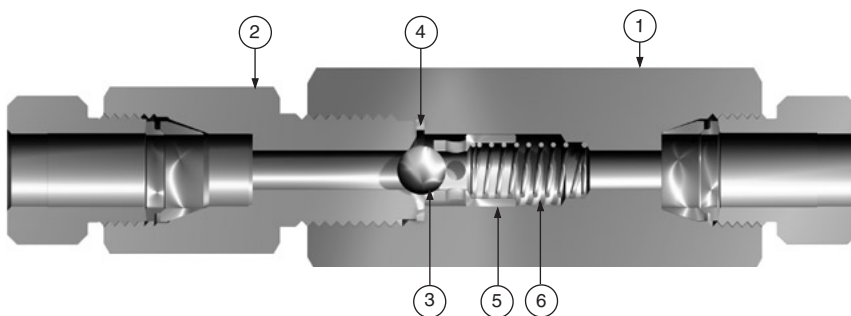

Materials of Construction

Item #	Part	Material
1	Cap	316SS
2	Body	316SS
3	3/8 Ball	316SS
4	Gasket	316SS
5	Ball Support	316SS
6	Spring	316SS

Poppet Check Valves

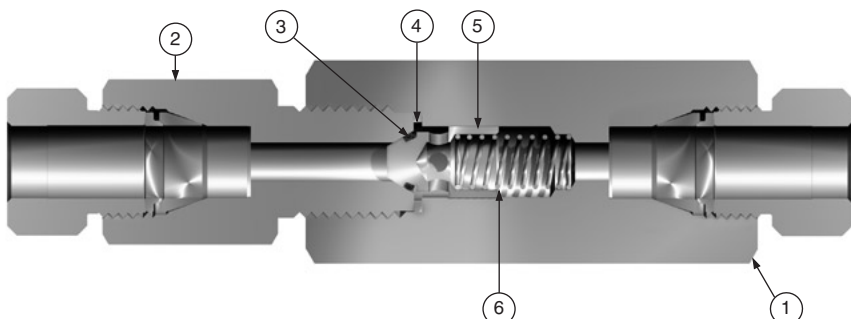

Materials of Construction

Item #	Part	Material
1	Cap	316SS
2	Body	316SS
3	O-Ring	Fluorocarbon Rubber*
4	Gasket	316SS
5	Poppet	316SS
6	Spring	316SS

*Optional Seal Materials

KZ	Highly Fluorinated Fluorocarbon Rubber
BN	Nitrile Rubber
EPR	Ethylene Propylene Rubber

MPR Series Relief Valves

Parker MPR series relief valves are offered in preset pressure relief ranges from 1500 to 20,999 psi. Relief valves are tagged with the proper factory preset pressures.

Relief Valves (Factory Set)

Parker Part Number	Pressure Rating PSI	Connection	Orifice Inch	Max Flow Capacity GPM
8M8F-MPRA-****-SS	1,500 to 2,999	1/2" M X F NPT	0.250	13
8M8F-MPRA-****-SS	3,000 to 10,999	1/2" M X F NPT	0.250	25
9HF8F-MPRA-****-SS	11,000 to 20,999	9HF X 1/2" F NPT	0.188	20

MEDIUM PRESSURE VALVES

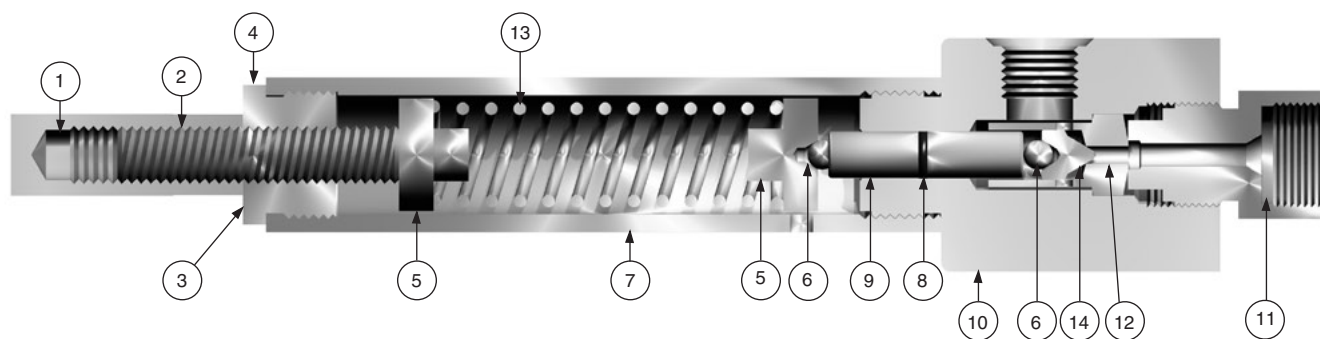

Materials of Construction

Item #	Qty	Part	Material
1	1	Cap	303SS
2	1	5/8-11 X 3 Soc Set Scr	304SS
3	1	Pressure Rating Tag	300 Ser. SS
4	1	Nut	303SS
5	2	Spring Seat	304SS
6	2	5/16 Ball	316SS
7	1	Spring Housing	304SS
8	1	O-Ring	Fluorocarbon Rubber*
9	1	Stem	17-4PH-H1150
10	1	Body	316SS
11	1	Removable Seat Gland	316SS
12	1	Seal Ring 1500 to 2999	316SS
		Seal Ring 3000 to 10999	316SS
		Seal Ring 11000 to 20999	316SS
13	1	Danly Spring	Steel
14	1	Stem Seat	17-4PH-H900

*Optional Seal Materials

KZ	Highly Fluorinated Fluorocarbon Rubber
BN	Nitrile Rubber
EPR	Ethylene Propylene Rubber

Example: 8M8F-MPRA-10000-KZ-SS

HB4 Series Ball Valves

Parker HB4 Series Ball Valves are engineered and manufactured to provide reliable shut-off or switching functions. Their compact and rugged design incorporates spring-loaded seats for high cycle life and low operating torques at pressures up to 10,000 psi (689 bar). Every HB4 Series Ball Valve is manufactured with Parker SUPARCASE® trunnions and ball to resist corrosion, seizures, and particle abrasion.

Specifications	
Pressure rating: 10,000 psi (689 bar) CWP with PEEK (PKR) Seats; 6,000 psi (414 bar) CWP with PCTFE (K) Seats	Body material: 204°C Stainless Steel Body configurations: Two-way and Three-way
Flow Data	
Two-way HB4L: $C_v = 1.02$; $x_T = 0.42$; Orifice = 0.188" (4.8 mm) Three-way HB4X: $C_v = 0.62$; $x_T = 0.71$; Orifice = 0.188" (4.8 mm)	

Tested in accordance with ISA S75.02. Gas flow will be choked when $P_1 - P_2 / P_1 = x_T$.

For additional information about the HB Series of Ball Valves, including flow data and pressure ratings, see Catalog 4121-HB or contact your authorized Parker Instrumentation Distributor or the Parker Hannifin Instrumentation Products Division at (256) 435-2130.

Tubing	Parker Part No. 2-Way	Parker Part No. 3-Way
1/4" O.D.	HB4PKR-SSP	4MP7-HB4XPKR-SSP
3/8" O.D.	HB6PKR-SSP	6MP7-HB4XPKR-SSP
9/16" O.D.	HB9PKR-SSP	9MP7-HB4XPKR-SSP

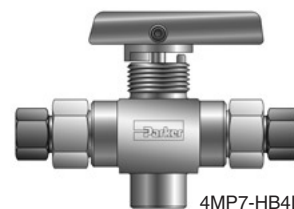

4MP7-HB4LPKR-SSP

MEDIUM PRESSURE VALVES

Double Block and Bleed Valves

Parker 15KSI DBB valves provide a unique double block and bleed valve with MPI™ integral ends. Designed to handle critical, high pressure applications, the valve is rated to 15,000 psi to meet the needs of severe applications in the offshore industry. The compact design eliminates the need for additional connections, piping, and associated weight found in traditional valve hook-ups. The Parker Tru-Lok locking mechanism on the MPI™ ends provide 100% security to prevent any connector movement when disconnecting instruments or connectors.

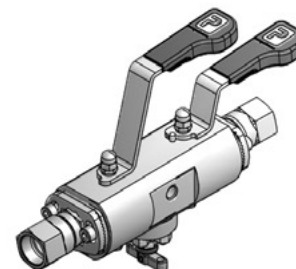

Features

- Manufactured from ASTM A479 316 stainless steel bar
- Ergonomic operating handles with low torque function
- Parker Tru-Lok safety system connections
- Firesafe to API 607

Specifications

Orifice	3/8" (10 mm)
Primary Valve	Bidirectional Ball Valve
Secondary Valves	Bidirectional Ball Valve
Vent	Needle Valve 1/4-18 NPT (FEM)
Inlet Connection	3/8", 9/16" and 3/4" O.D. Tube MPI™
Outlet Connection	3/8", 9/16" and 3/4" O.D. Tube MPI™
Weight	6.25kg
MCWP	15,000 PSI (1034 Bar)
Max. Temp.	450 °F (232°C)

Materials of Construction

Description	Material
Body	316SS
Trim	316SS
Needle Valve Tip	17/4 PH
Ball Valve Seats	PHlex
Ball Valve Packing	PEEK/PTFE
Needle Valve Packing	PTFE

Dimensions

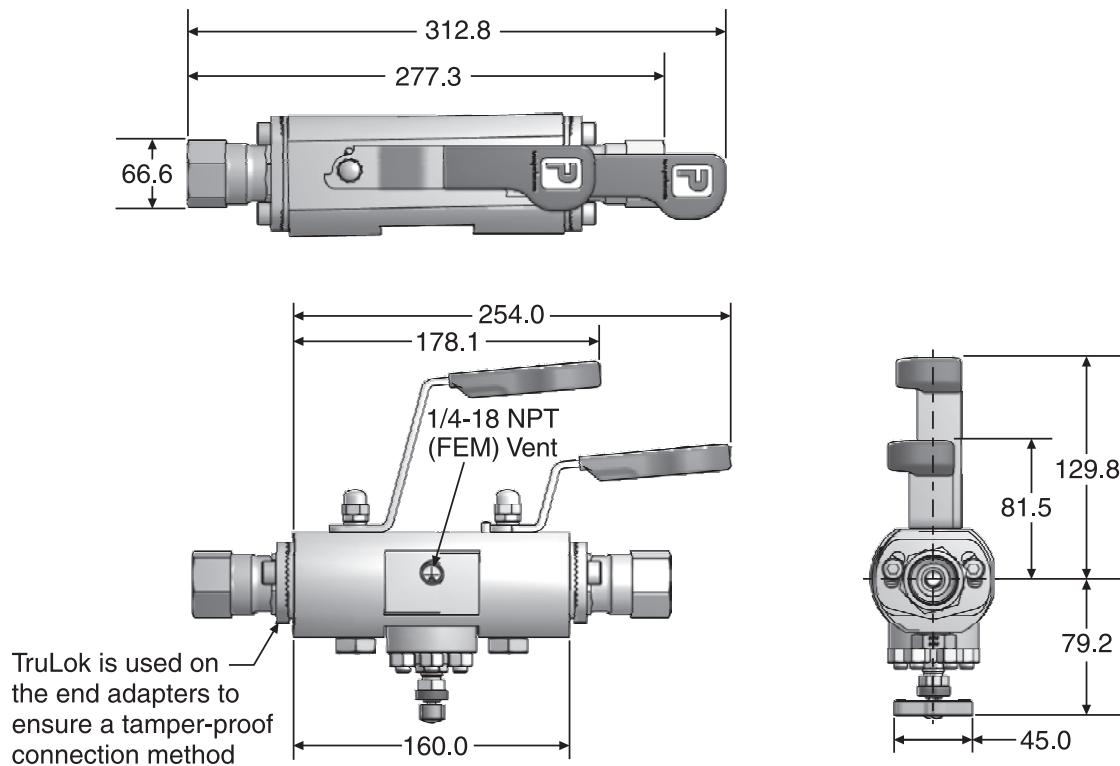

MEDIUM PRESSURE VALVES

15,000 PSI, Ultra High Flow Ball Valves

Parker's High Flow Ball Valve provides high flow rates without sacrificing working pressures. The 2507 Super Duplex body provides the strength necessary for medium pressure applications. End connections are Parker's MPI™ (Medium Pressure Inverted) fittings which allows for quick installation and dependable service. Parker's Parofluor™ V8588-90 perfluorinated elastomer seals resist the aggressive chemical media common to the oil and gas industries. (See Parker O-Ring Division Technical Bulletin No. 5722B1-USA for complete details and test data.)

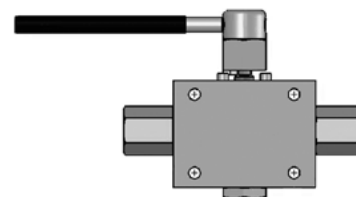

Features

- Bi-directional trunnion style closure
- Blow out proof stem
- Optional packing, seal, spring, and seat materials available (consult factory for available options)
- 4 hole rack mount bolt pattern
- For applications up to 15,000 PSI
- .47" Orifice for high flow

Specifications

Working Pressure	up to 15,000 PSI
Orifice	.47" (10 mm)
Standard Connections	Parker MPI™ Fittings
Weight	6.25kg
Typical Application	Chemical Injection Skids
Typical Materials	<ul style="list-style-type: none"> • 316 cold-worked stainless steel trim • 2507 Super Duplex body • Fiber-reinforced PEEK seats • Parker Parofluor™ perfluorinated elastomer seals

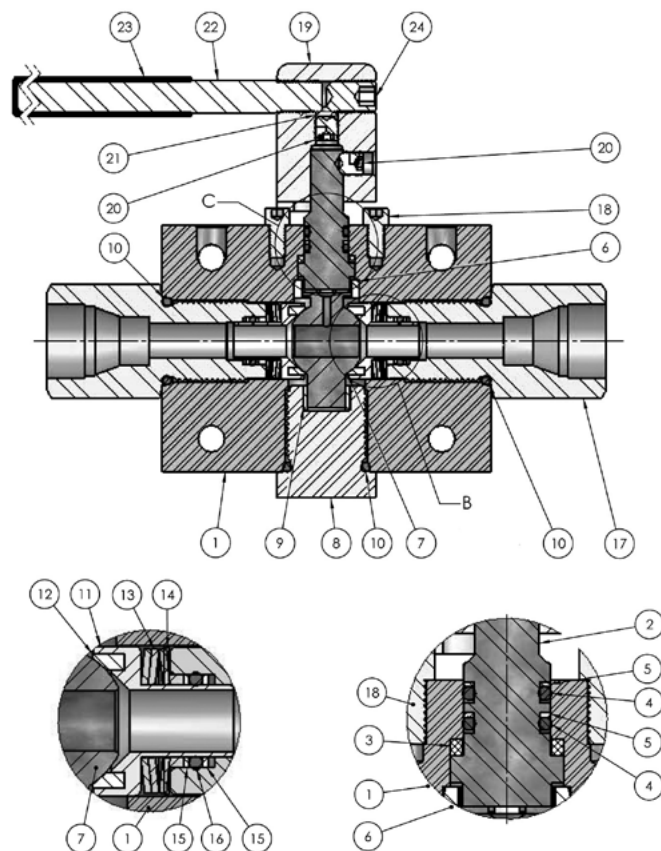

Materials of Construction

Item #	Description	Material
1	Body	Duplex 2507
2	Stem	Inconel 625
3	Bearing Washer	Nitronic 60
4	UNIF-112 O-Ring	V8588-90
5	UNIF-112 Backup Ring	PEEK
6	Top Bearing	Nitronic 60
7	Trunnion	316L SS CW
8	Bottom Blank	316L SS CW
9	Bottom Bearing	Nitronic 60
10	UNIF-215 O-Ring	V8588-90
11	Seat Retainer	17-4 PH H900
12	Seat Seal	30% GF PEEK
13	Spring Washer	Inconel 718
14	Follower	316L SS CW
15	UNIF-113 Backup Ring	PEEK
16	UNIF-113 O-Ring	V8588-90
17	End Adapter / # 12MPI	316L SS CW
18	Socket Head Cap Screw	316 SS
19	Hub	316L SS CW
20	Knurled Set Screw	18-8 SS
21	Thread Disc	Nylatron
22	Handle	316L SS CW
23	Handle Grip	PVC
24	Socket Set Screw	18-8 SS

MEDIUM PRESSURE VALVES

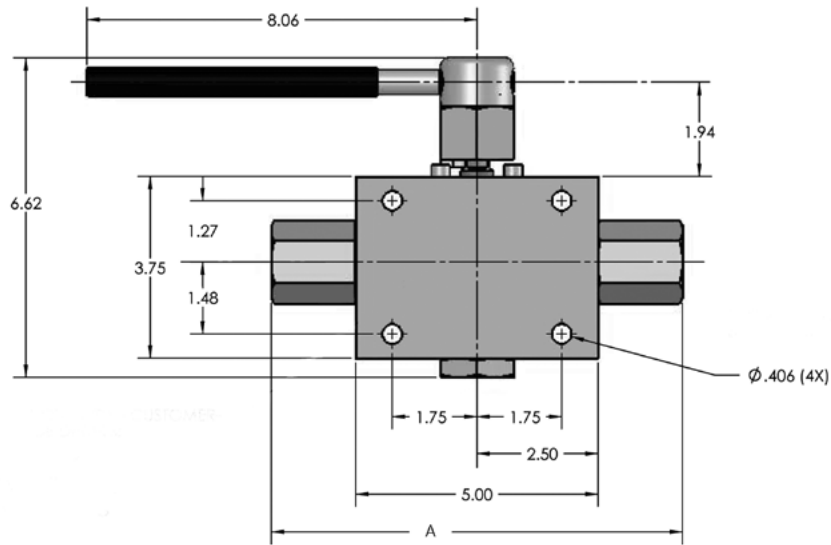

Dimensions

Size	Parker Part Number	PSI	Connection	Inches			
				Orifice	Minimum Orifice	Cv	A
Ultra High Flow (UH)							
3/4"	12MP7-MPBLPKPUH-KZ*-SSP	15,000	3/4" MPI	0.470	0.470	7.6	8.51
1"	16MP7-MPBLPKPUH-KZ*-SSP	12,500	1" MPI	0.470	0.470	7.6	10.13

* Perfluorinated elastomer is standard. Please consult the factory for optional materials.

Tee Handle Option*

Dimensions

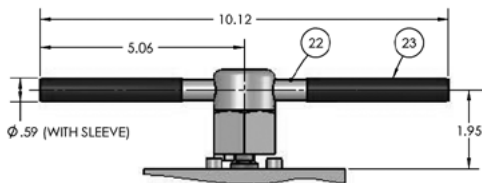

Materials of Construction

(Items 1-21 same as standard part, shown on [previous page](#))

Item #	Description	Material
22	Handle**	316L SS CW
23	Handle Grip	PVC

* To order the Stainless Steel Tee Handle option, add "-ST" to the end of the part number.

Assembly

1. Parker MPI™ Fittings are sold completely assembled and ready for immediate use. Simply insert the tube as illustrated until it bottoms in the fitting body. (If the fitting is disassembled, note that the small tapered end of the ferrule(s) go into the fitting body.)
2. Turn the nut to the “finger-tight” position. Hold the fitting body with a second wrench to prevent the body from turning as you tighten the nut. For hand assembly, tighten the nut 1-1/2 turns. For 3/4" and 1" sizes, preset the nut and ferrules and then tighten the nut 1/2 turn only. See [page 45](#) for more information on preset connections. Parker recommends that you mark the nut (using a scribe or ink) to help you count the turns.

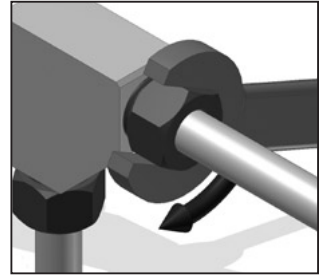
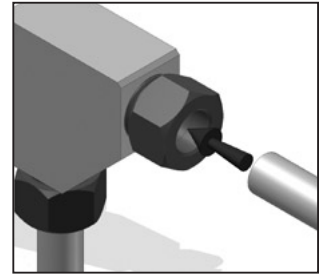

Gaugeability

Check the gap between the nut and the body hex with the end of the gauge by inserting the gauge (as shown) into the beveled gap between the nut and body hex. Gently turn the gauge (that is, it “twists out”). However, if the gauge slides into the beveled gap, (does not “twist out”) the fitting is not properly made up and you must check the entire assembly procedure.



Remake

For maximum number of remakes, mark the fitting and nut before disassembly. Before retightening, make sure the assembly has been inserted into the fitting until the ferrule seats in the fitting. Retighten the nut by hand. Rotate the nut with a wrench to the original position as indicated by the previous marks lining up. (A noticeable increase in mechanical resistance will be felt indicating the ferrule is being re-sprung into sealing position.)

MPI™ Hydraulic Preset Tools

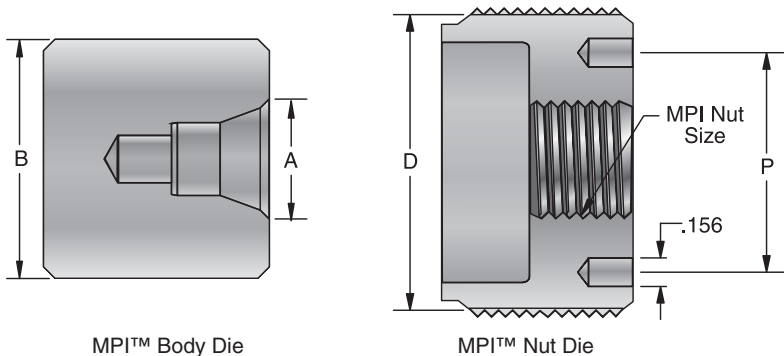

MPI™ Body Die

MPI™ Nut Die

Body Dies and Nut Dies Used with the MPI™ Small Preset Assembly

MPI Small Preset Assembly		Inches					MPI™ Nut Size	Preset Pressure (PSIG)
Body Die Part No.	Nut Die Part No.	A	B	D	P			
4 MPI Body Die	4 MPI Nut Die	.50	1.25	1.62	1.20	4	3,200	
6 MPI Body Die	6 MPI Nut Die	.63	1.25	1.62	1.20	6	4,000	
8 MPI Body Die	8 MPI Nut Die	.82	1.25	1.62	1.20	8	6,800	
9 MPI Body Die	9 MPI Nut Die	.88	1.25	1.62	1.20	9	8,500	

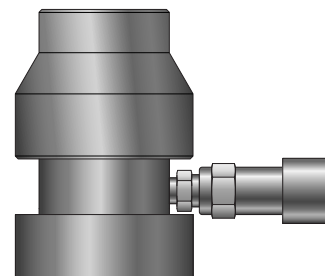

Parker Part No.
MPI Small Preset Assembly

Body Dies and Nut Dies Used with the MPI™ Large Preset Assembly

MPI Large Preset Assembly		Inches					MPI™ Nut Size	Preset Pressure (PSIG)
Body Die Part No.	Nut Die Part No.	A	B	D	P			
*9 MPI Body Die	9 MPI Large Nut Die	.88	1.25	2.00	1.67	9	3,600	
12 MPI Body Die	12 MPI Nut Die	1.13	1.75	2.00	1.67	12	5,100	
16 MPI Body Die	16 MPI Nut Die	1.44	1.75	2.00	1.67	16	8,000	

* Requires a 9 MPI Body Die Adapter

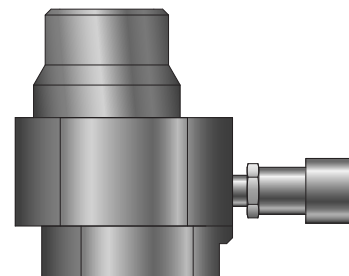

Parker Part No.
MPI LARGE Preset Assembly

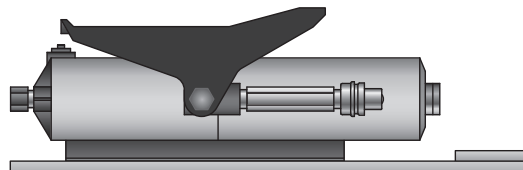

Parker Part No.
MPI AIR PUMP KIT

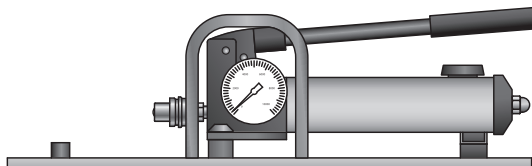

Parker Part No.
MPI HAND PUMP KIT

Note: One Pump Kit, Preset Assembly, Body Die and Nut Die are required for presetting. Pump Kits and Preset Assemblies can be interchanged but Body Dies and Nut Dies are for a specific Preset Assembly. Detailed operating instructions are included with each kit. Copies may also be obtained by contacting the Division.

TECHNICAL INFORMATION

Terms of Sale with Warranty Limitations

The items described in this document and other documents and descriptions provided by Parker Hannifin Corporation, its subsidiaries and its authorized distributors ("Seller") are hereby offered for sale at prices to be established by Seller. This offer and its acceptance by any customer ("Buyer") shall be governed by all of the following Terms and Conditions. Buyer's order for any item described in its document, when communicated to Seller verbally, or in writing, shall constitute acceptance of this offer. All goods or work described will be referred to as "Products".

1. Terms and Conditions. Seller's willingness to offer Products, or accept an order for Products, to or from Buyer is expressly conditioned on Buyer's assent to these Terms and Conditions and to the terms and conditions found on-line at www.parker.com/saleterms/. Seller objects to any contrary or additional term or condition of Buyer's order or any other document issued by Buyer.

2. Price Adjustments; Payments. Prices stated on the reverse side or preceding pages of this document are valid for 30 days. After 30 days, Seller may change prices to reflect any increase in its costs resulting from state, federal or local legislation, price increases from its suppliers, or any change in the rate, charge, or classification of any carrier. The prices stated on the reverse or preceding pages of this document do not include any sales, use, or other taxes unless so stated specifically. Unless otherwise specified by Seller, all prices are F.O.B. Seller's facility, and payment is due 30 days from the date of invoice. After 30 days, Buyer shall pay interest on any unpaid invoices at the rate of 1.5% per month or the maximum allowable rate under applicable law.

3. Delivery Dates; Title and Risk; Shipment. All delivery dates are approximate and Seller shall not be responsible for any damages resulting from any delay. Regardless of the manner of shipment, title to any products and risk of loss or damage shall pass to Buyer upon tender to the carrier at Seller's facility (i.e., when it's on the truck, it's yours). Unless otherwise stated, Seller may exercise its judgment in choosing the carrier and means of delivery. No deferment of shipment at Buyers' request beyond the respective dates indicated will be made except on terms that will indemnify, defend and hold Seller harmless against all loss and additional expense. Buyer shall be responsible for any additional shipping charges incurred by Seller due to Buyer's changes in shipping, product specifications or in accordance with Section 13, herein.

4. Warranty. Seller warrants that the Products sold hereunder shall be free from defects in material or workmanship for a period of twelve months from the date of delivery to Buyer or 2,000 hours of normal use, whichever occurs first. This warranty is made only to Buyer and does not extend to anyone to whom Products are sold after purchased from Seller. The prices charged for Seller's products are based upon the exclusive limited warranty stated above, and upon the following disclaimer: **DISCLAIMER OF WARRANTY: THIS WARRANTY COMPRISES THE SOLE AND ENTIRE WARRANTY PERTAINING TO PRODUCTS PROVIDED HEREUNDER. SELLER DISCLAIMS ALL OTHER WARRANTIES, EXPRESS AND IMPLIED, INCLUDING MERCHANTABILITY AND FITNESS FOR A PARTICULAR PURPOSE.**

5. Claims; Commencement of Actions. Buyer shall promptly inspect all Products upon delivery. No claims for shortages will be allowed unless reported to the Seller within 10 days of delivery. No other claims against Seller will

be allowed unless asserted in writing within 60 days after delivery or, in the case of an alleged breach of warranty, within 30 days after the date within the warranty period on which the defect is or should have been discovered by Buyer. Any action based upon breach of this agreement or upon any other claim arising out of this sale (other than an action by Seller for any amount due to Seller from Buyer) must be commenced within thirteen months from the date of tender of delivery by Seller or, for a cause of action based upon an alleged breach of warranty, within thirteen months from the date within the warranty period on which the defect is or should have been discovered by Buyer.

6. LIMITATION OF LIABILITY. UPON NOTIFICATION, SELLER WILL, AT ITS OPTION, REPAIR OR REPLACE A DEFECTIVE PRODUCT, OR REFUND THE PURCHASE PRICE. IN NO EVENT SHALL SELLER BE LIABLE TO BUYER FOR ANY SPECIAL, INDIRECT, INCIDENTAL OR CONSEQUENTIAL DAMAGES ARISING OUT OF, OR AS THE RESULT OF, THE SALE, DELIVERY, NON-DELIVERY, SERVICING, USE OR LOSS OF USE OF THE PRODUCTS OR ANY PART THEREOF, OR FOR ANY CHARGES OR EXPENSES OF ANY NATURE INCURRED WITHOUT SELLER'S WRITTEN CONSENT, EVEN IF SELLER HAS BEEN NEGLIGENT, WHETHER IN CONTRACT, TORT OR OTHER LEGAL THEORY. IN NO EVENT SHALL SELLER'S LIABILITY UNDER ANY CLAIM MADE BY BUYER EXCEED THE PURCHASE PRICE OF THE PRODUCTS.

7. Contingencies. Seller shall not be liable for any default or delay in performance if caused by circumstances beyond the reasonable control of Seller.

8. User Responsibility. The user, through its own analysis and testing, is solely responsible for making the final selection of the system and Product and assuring that all performance, endurance, maintenance, safety and warning requirements of the application are met. The user must analyze all aspects of the application and follow applicable industry standards and Product information. If Seller provides Product or system options, the user is responsible for determining that such data and specifications are suitable and sufficient for all applications and reasonably foreseeable uses of the Products or systems.

9. Loss to Buyer's Property. Any designs, tools, patterns, materials, drawings, confidential information or equipment furnished by Buyer or any other items which become Buyer's property, may be considered obsolete and may be destroyed by Seller after two consecutive years have elapsed without Buyer placing an order for the items which are manufactured using such property. Seller shall not be responsible for any loss or damage to such property while it is in Seller's possession or control.

10. Special Tooling. A tooling charge may be imposed for any special tooling, including without limitation, dies, fixtures, molds and patterns, acquired to manufacture Products.

Such special tooling shall be and remain Seller's property notwithstanding payment of any charges by Buyer. In no event will Buyer acquire any interest in apparatus belonging to Seller which is utilized in the manufacture of the Products, even if such apparatus has been specially converted or adapted for such manufacture and notwithstanding any charges paid by Buyer. Unless otherwise agreed, Seller shall have the right to alter, discard or otherwise dispose of any special tooling or other property in its sole discretion at any time.

11. Buyer's Obligation; Rights of Seller. To secure payment of all sums due or otherwise, Seller shall retain a security interest in the goods delivered and this agreement shall be deemed a Security Agreement under the Uniform Commercial Code. Buyer authorizes Seller as its attorney to execute and file on Buyer's behalf all documents Seller deems necessary to perfect its security interest. Seller shall have a security interest in, and lien upon, any property of Buyer in Seller's possession as security for the payment of any amounts owed to Seller by Buyer.

12. Improper use and Indemnity. Buyer shall indemnify, defend, and hold Seller harmless from any claim, liability, damages, lawsuits, and costs (including attorney fees), whether for personal injury, property damage, patent, trademark or copyright infringement or any other claim, brought by or incurred by Buyer, Buyer's employees, or any other person, arising out of: (a) improper selection, improper application or other misuse of Products purchased by Buyer from Seller; (b) any act or omission, negligent or otherwise, of Buyer; (c) Seller's use of patterns, plans, drawings, or specifications furnished by Buyer to manufacture Product; or (d) Buyer's failure to comply with these terms and conditions. Seller shall not indemnify Buyer under any circumstance except as otherwise provided.

13. Cancellations and Changes. Orders shall not be subject to cancellation or change by Buyer for any reason, except with Seller's written consent and upon terms that will indemnify, defend and hold Seller harmless against all direct, incidental and consequential loss or damage. Seller may change product features, specifications, designs and availability with notice to Buyer.

14. Limitation on Assignment. Buyer may not assign its rights or obligations under this agreement without the prior written consent of Seller.

15. Entire Agreement. This agreement contains the entire agreement between the Buyer and Seller and constitutes the final, complete and exclusive expression of the terms of the agreement. All prior or contemporaneous written or oral agreements or negotiations with respect to the subject matter are herein merged.

16. Waiver and Severability. Failure to enforce any provision of this agreement will not waive that provision nor will any such failure prejudice Seller's right to enforce that provision in the future. Invalidation of any provision of this agreement by legislation or other rule of law shall not invalidate any other provision herein. The remaining provisions of this agreement will remain in full force and effect.

17. Termination. This agreement may be terminated by Seller for any reason and at any time by giving Buyer thirty (30) days written notice of termination. In addition, Seller may

by written notice immediately terminate this agreement for the following: (a) Buyer commits a breach of any provision of this agreement (b) the appointment of a trustee, receiver or custodian for all or any part of Buyer's property (c) the filing of a petition for relief in bankruptcy of the other Party on its own behalf, or by a third party (d) an assignment for the benefit of creditors, or (e) the dissolution or liquidation of the Buyer.

18. Governing Law. This agreement and the sale and delivery of all Products hereunder shall be deemed to have taken place in and shall be governed and construed in accordance with the laws of the State of Ohio, as applicable to contracts executed and wholly performed therein and without regard to conflicts of laws principles. Buyer irrevocably agrees and consents to the exclusive jurisdiction and venue of the courts of Cuyahoga County, Ohio with respect to any dispute, controversy or claim arising out of or relating to this agreement. Disputes between the parties shall not be settled by arbitration unless, after a dispute has arisen, both parties expressly agree in writing to arbitrate the dispute.

19. Indemnity for Infringement of Intellectual Property Rights. Seller shall have no liability for infringement of any patents, trademarks, copyrights, trade dress, trade secrets or similar rights except as provided in this Section. Seller will defend and indemnify Buyer against allegations of infringement of U.S. patents, U.S. trademarks, copyrights, trade dress and trade secrets ("Intellectual Property Rights"). Seller will defend at its expense and will pay the cost of any settlement or damages awarded in an action brought against Buyer based on an allegation that a Product sold pursuant to this Agreement infringes the Intellectual Property Rights of a third party. Seller's obligation to defend and indemnify Buyer is contingent on Buyer notifying Seller within ten (10) days after Buyer becomes aware of such allegations of infringement, and Seller having sole control over the defense of any allegations or actions including all negotiations for settlement or compromise. If a Product is subject to a claim that it infringes the Intellectual Property Rights of a third party, Seller may, at its sole expense and option, procure for Buyer the right to continue using the Product, replace or modify the Product so as to make it noninfringing, or offer to accept return of the Product and return the purchase price less a reasonable allowance for depreciation. Notwithstanding the foregoing, Seller shall have no liability for claims of infringement based on information provided by Buyer, or directed to Products delivered hereunder for which the designs are specified in whole or part by Buyer, or infringements resulting from the modification, combination or use in a system of any Product sold hereunder. The foregoing provisions of this Section shall constitute Seller's sole and exclusive liability and Buyer's sole and exclusive remedy for infringement of Intellectual Property Rights.

20. Taxes. Unless otherwise indicated, all prices and charges are exclusive of excise, sales, use, property, occupational or like taxes which may be imposed by any taxing authority upon the manufacture, sale or delivery of Products.

21. Equal Opportunity Clause. For the performance of government contracts and where dollar value of the Products exceed \$10,000, the equal employment opportunity clauses in Executive Order 11246, VEVRAA, and 41 C.F.R. §§ 60-1.4(a), 60-741.5(a), and 60-250.4, are hereby incorporated.

Parker's Motion & Control Technologies

At Parker, we're guided by a relentless drive to help our customers become more productive and achieve higher levels of profitability by engineering the best systems for their requirements. It means looking at customer applications from many angles to find new ways to create value. Whatever the motion and control technology need, Parker has the experience, breadth of product and global reach to consistently deliver. No company knows more about motion and control technology than Parker. For further info call 1-800-C-Parker.



AEROSPACE

Key Markets

- Aircraft engines
- Business & general aviation
- Commercial transports
- Land-based weapons systems
- Military aircraft
- Missiles & launch vehicles
- Regional transports
- Unmanned aerial vehicles

Key Products

- Flight control systems & components
- Fluid conveyance systems
- Fluid metering delivery & atomization devices
- Fuel systems & components
- Hydraulic systems & components
- Inert nitrogen generating systems
- Pneumatic systems & components
- Wheels & brakes



CLIMATE CONTROL

Key Markets

- Agriculture
- Air conditioning
- Food, beverage & dairy
- Life sciences & medical
- Precision cooling
- Processing
- Transportation

Key Products

- CO₂ controls
- Electronic controllers
- Filter driers
- Hand shut-off valves
- Hose & fittings
- Pressure regulating valves
- Refrigerant distributors
- Safety relief valves
- Solenoid valves
- Thermostatic expansion valves

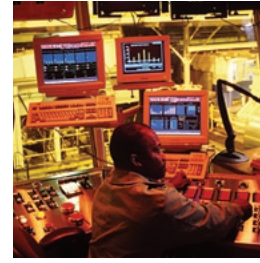

ELECTROMECHANICAL

Key Markets

- Aerospace
- Factory automation
- Life science & medical
- Machine tools
- Packaging machinery
- Paper machinery
- Plastics machinery & converting
- Primary metals
- Semiconductor & electronics
- Textile
- Wire & cable

Key Products

- AC/DC drives & systems
- Electric actuators, gantry robots & slides
- Electrohydraulic actuation systems
- Electromechanical actuation systems
- Human machine interface
- Linear motors
- Stepper motors, servo motors, drives & controls
- Structural extrusions



FILTRATION

Key Markets

- Food & beverage
- Industrial machinery
- Life sciences
- Marine
- Mobile equipment
- Oil & gas
- Power generation
- Process
- Transportation

Key Products

- Analytical gas generators
- Compressed air & gas filters
- Condition monitoring
- Engine air, fuel & oil filtration & systems
- Hydraulic, lubrication & coolant filters
- Process, chemical, water & microfiltration filters
- Nitrogen, hydrogen & zero air generators



FLUID & GAS HANDLING

Key Markets

- Aerospace
- Agriculture
- Bulk chemical handling
- Construction machinery
- Food & beverage
- Fuel & gas delivery
- Industrial machinery
- Mobile
- Oil & gas
- Transportation
- Welding

Key Products

- Brass fittings & valves
- Diagnostic equipment
- Fluid conveyance systems
- Industrial hose
- PTFE & PFA hose, tubing & plastic fittings
- Rubber & thermoplastic hose & couplings
- Tube fittings & adapters
- Quick disconnects



HYDRAULICS

Key Markets

- Aerospace
- Aerial lift
- Agriculture
- Construction machinery
- Forestry
- Industrial machinery
- Mining
- Oil & gas
- Power generation & energy
- Truck hydraulics

Key Products

- Diagnostic equipment
- Hydraulic cylinders & accumulators
- Hydraulic motors & pumps
- Hydraulic systems
- Hydraulic valves & controls
- Power take-offs
- Rubber & thermoplastic hose & couplings
- Tube fittings & adapters
- Quick disconnects

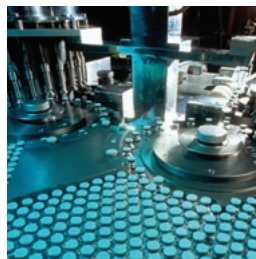

PNEUMATICS

Key Markets

- Aerospace
- Conveyor & material handling
- Factory automation
- Life science & medical
- Machine tools
- Packaging machinery
- Transportation & automotive

Key Products

- Air preparation
- Brass fittings & valves
- Manifolds
- Pneumatic accessories
- Pneumatic actuators & grippers
- Pneumatic valves & controls
- Quick disconnects
- Rotary actuators
- Rubber & thermoplastic hose & couplings
- Structural extrusions
- Thermoplastic tubing & fittings
- Vacuum generators, cups & sensors



PROCESS CONTROL

Key Markets

- Chemical & refining
- Food, beverage & dairy
- Medical & dental
- Microelectronics
- Oil & gas
- Power generation

Key Products

- Analytical sample conditioning products & systems
- Fluoropolymer chemical delivery fittings, valves & pumps
- High purity gas delivery fittings, valves & regulators
- Instrumentation fittings, valves & regulators
- Medium pressure fittings & valves
- Process control manifolds



SEALING & SHIELDING

Key Markets

- Aerospace
- Chemical processing
- Consumer
- Energy, oil & gas
- Fluid power
- General industrial
- Information technology
- Life sciences
- Military
- Semiconductor
- Telecommunications
- Transportation

Key Products

- Dynamic seals
- Elastomeric o-rings
- EMI shielding
- Extruded & precision-cut, fabricated elastomeric seals
- Homogeneous & inserted elastomeric shapes
- High temperature metal seals
- Metal & plastic retained composite seals
- Thermal management



ENGINEERING YOUR SUCCESS.

Sales Offices Worldwide

Parker Hannifin Corporation

Instrumentation Products Division
1005 A Cleaner Way
Huntsville, AL 35805
USA
phone 256 881 2040
fax 256 8815072
www.parker.com/ipdus

Parker Hannifin Corporation

Instrumentation Products Division
2651 Alabama Highway 21 North
Jacksonville, AL 36265-9681
USA
phone 256 435 2130
fax 256 435 7718
www.parker.com/ipdus

Parker Hannifin Corporation

Instrumentation Products Division
6575 Tram Road
Beaumont, TX 77713
USA
phone 409 924 0300
fax 409 924 0301
www.parker.com/ipdus

Parker Hannifin plc

Instrumentation Products Division
Riverside Road
Pottington Business Park
Barnstaple, Devon EX31 1NP
England
phone +44 0 1271 313131
fax +44 0 1271 373636
email ipd@parker.com
www.parker.com/ipd

Catalog 4234 15M August 2010 Duke



Parker Hannifin Corporation
Instrumentation Products Division
1005 A Cleaner Way
Huntsville, AL 35805
phone 256 881 2040
fax 256 881 5072
www.parker.com/ipdus

Your Local Authorized Parker Distributor