

Level sensor with reed measuring chain Model FLR, for the process industry

WIKA data sheet LM 20.02



for further approvals
see page 3



Applications

- Level measurement for almost all liquid media
- Chemical, petrochemical industry, natural gas, offshore, shipbuilding, machine building, power generating equipment, power plants
- Process water and drinking water treatment, food and beverage industry, pharmaceutical industry

Special features

- Process- and system-specific solutions possible
- Operating limits:
 - Operating temperature: $T = -80 \dots +200 \text{ }^\circ\text{C}$
 - Operating pressure: $P = \text{Vacuum up to } 80 \text{ bar}$
 - Limit density: $\rho \geq 400 \text{ kg/m}^3$
- Wide variety of different electrical connections, process connections and materials
- Optionally with programmable and configurable head-mounted transmitter for 4 ... 20 mA field signals, HART®, PROFIBUS® PA and FOUNDATION™ Fieldbus
- Explosion-protected versions

Description

The model FLR sensors with reed measuring chain are used for level measurement in liquid media. They work on the float principle with magnetic transmission.

The float's magnetic system in the guide tube actuates a resistance measuring chain that corresponds to a 3-wire potentiometer circuit. The measurement voltage generated by this is proportional to the fill level.

The measurement voltage is very finely-stepped due to the contact separation of the measuring chain and is thus virtually continuous. Depending on the requirements several different contact separations are available.



Level sensor with reed measuring chain, flange connection with stainless steel connection housing, model FLR-SAI (NMG125)

Internal circuit diagram of the reed sensors

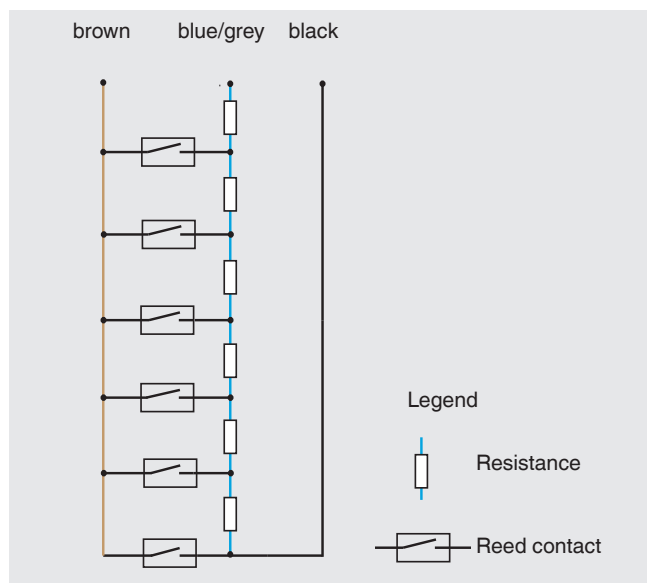

Model overview









Sensor model	Description	Materials										
		Stainless steel						Titanium 3.7035 (grade 2)	PVC	PP	PVDF	Buna
		1.4571 (316Ti)	1.4404 (316L)	1.4435 (316L)	1.4571 (316Ti) / PP	1.4571 (316Ti) / PA	1.4571 (316Ti) / Ms					
FLR-S	Standard version	x	x	x	x	x	x	x				x
FLR-P	Plastic version								x	x	x	
FLR-H	Sterile version		x	x								

Temperature range (process)



- Model FLR-S -80 ... +200 °C
- Model FLR-P -10 ... +100 °C
- Model FLR-H -20 ... +200 °C

Approvals





■ Model FLR-S

Logo	Description	Country
	EU declaration of conformity <ul style="list-style-type: none"> ■ EMC directive EN 61326 emission (group 1, class B) and interference immunity (industrial application) ■ RoHS directive ■ ATEX directive (option) Hazardous areas - Ex i II 1/2G Ex ia IIC T4 ... T6 Ga/Gb oder No. KEMA 01 ATEX 1052 X II 2D Ex ib IIIC T80 °C Db - Ex d II 2G Ex d IIC T6 Gb / II 2 D Ex tb IIIC T80 °C Db No. TÜV 13 ATEX 7399 X 	European Union
	IECEX (option) Hazardous areas - Ex d Zone 1/2 -40 °C ≤ Ta ≤ +55 °C No. IECEx TUR 09.0002X Ex d IIC T6 Ex tD A21 IP65 T80 °C	International
	EAC <ul style="list-style-type: none"> ■ EMC directive No. TC N RU Д-DE.A301.B.00820 ■ Hazardous areas No. RU C-DE.ГБ08.B.01489 	Eurasian Economic Community
	GOST Metrology, measurement technology No. 19358	Russia
	KazInMetr Metrology, measurement technology No. 13946	Kazakhstan
	BelGIM Metrology, measurement technology No. 9711	Belarus
	UkrSEPRO Metrology, measurement technology No. UA-MI/2-4989-2015	Ukraine
	Uzstandard Metrology, measurement technology No. 02.6648	Uzbekistan
-	PESO Hazardous areas No. P331149/1	India
	GL <ul style="list-style-type: none"> ■ Ships, shipbuilding ■ Hazardous areas - Ex i Zone 1/2 II 1/2G Ex ia IIC T4 ... T6 - II 2 D T80 °C IP6x No. GL-14788-99 HH 	International
	DNV <ul style="list-style-type: none"> ■ Ships, shipbuilding ■ Hazardous areas - Ex i Zone 1/2 II 1/2G Ex ia IIC T4 ... T6 - II 2 D T80 °C IP6x No. DNV-A-13735 	International
	Bureau Veritas Ships, shipbuilding No. 04263/G0 BV	International

■ Model FLR-P

Logo	Description	Country
	EU declaration of conformity <ul style="list-style-type: none"> ■ EMC directive (model FLR-PB) EN 61326 emission (group 1, class B) and interference immunity (industrial application) ■ RoHS directive 	European Union
	EAC EMC directive No. TC N RU Д-DE.A301.B.00820	Eurasian Economic Community

■ Model FLR-H

Logo	Description	Country
	EU declaration of conformity <ul style="list-style-type: none"> ■ EMC directive (model FLR-PB) EN 61326 emission (group 1, class B) and interference immunity (industrial application) ■ RoHS directive 	European Union
	EAC EMC directive No. TC N RU Д-DE.A301.B.00820	Eurasian Economic Community
	GOST Metrology, measurement technology No. 19358	Russia
	3-A Sanitary Standard No. 1698	USA

Approvals and certificates, see website

Sensor, standard version with connection housing Models FLR-SA, FLR-SB

Process connection, guide tube and float from stainless steel

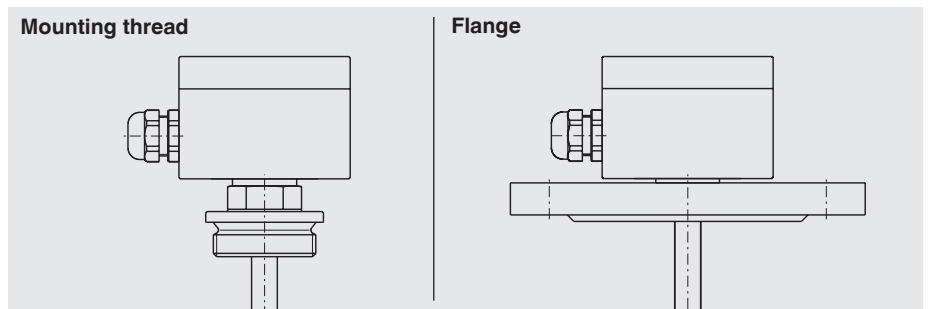
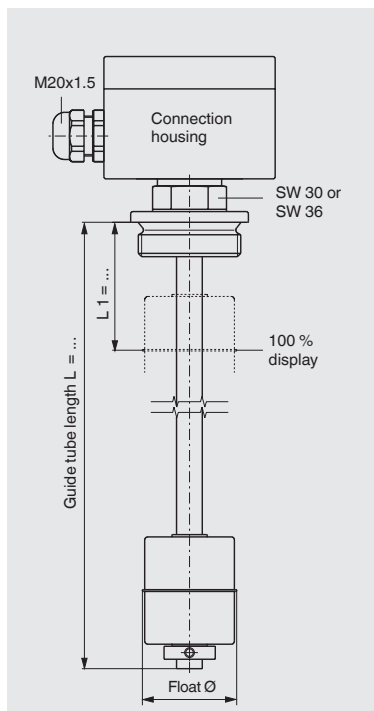

	Model FLR-SA	Model FLR-SB
Electrical connection	Connection housing: Aluminium 80 x 75 x 57 mm Option: Polypropylene, polyester, stainless steel	Connection housing: Aluminium 80 x 75 x 57 mm with head-mounted transmitter Option: Polypropylene, polyester, stainless steel
Process connection	<ul style="list-style-type: none"> ■ Mounting thread downwards G 1 1/2" or G 2" ■ Mounting flange <ul style="list-style-type: none"> - DIN DN 50 ... DN 200, PN 6 ... PN 100 - ANSI 2" ... 8", class 150 ... 600 	
Guide tube diameter	8 mm / 12 mm / 14 mm / 18 mm	
Max. guide tube length L	<ul style="list-style-type: none"> ■ 500 mm (guide tube diameter 8 mm) ■ 3,000 mm (guide tube diameter 12 or 14 mm) ■ 6,000 mm (guide tube diameter 18 mm) 	
Float	Material: Stainless steel 1.4571 (option: Buna, titanium) Float diameter: 44 ... 120 mm Float selection depending on guide tube diameter and process conditions (see page 15 and 16)	
Max. operating pressure	80 bar (see page 15 and 16)	
Temperature range	-20 ... +120 °C Option: <ul style="list-style-type: none"> ■ High-temperature version: +120 ... +200 °C ■ Low-temperature version: -80 ... -20 °C 	
Resolution	2.7 mm / 5.5 mm / 7.5 mm / 9 mm (depending on contact separation)	
Overall resistance of the measuring chain	Depending on length and separation	
Head-mounted transmitter	External transmitter	Head-mounted transmitter, see page 18
Output	3-wire potentiometer	4 ... 20 mA
Connection cable to transmitter / control room	Cable length max. 2,000 m, 3-wire, screened	2-wire, screened
Permissible power supply	< AC 50 V, < DC 75 V	see the data sheet of the head-mounted transmitter used
Mounting position	Vertical ±30°	
Ingress protection	up to IP66 or IP68 per IEC/EN 60529 (depending on version)	

Sensor, ECTFE coated version with connection housing Models FLR-SA, FLR-SB

Process connection, guide tube material and float from stainless steel 1.4571, ECTFE coated

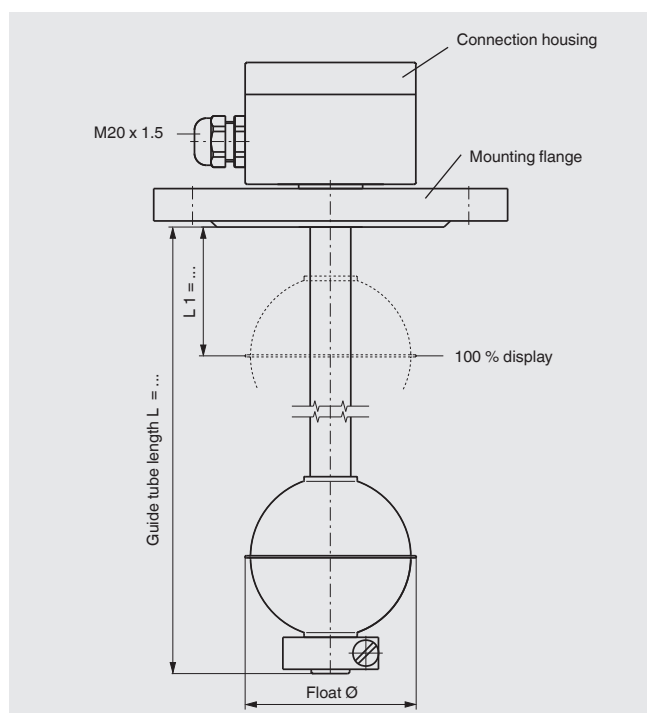

	Model FLR-SA	Model FLR-SB
Electrical connection	Connection housing: Aluminium 80 x 75 x 57 mm Option: Polypropylene, polyester, stainless steel	Connection housing: Aluminium 80 x 75 x 57 mm with head-mounted transmitter Option: Polypropylene, polyester, stainless steel
Process connection	Mounting flange <ul style="list-style-type: none"> ■ DIN DN 50 ... DN 200, PN 6 ... PN 100 ■ ANSI 2" ... 8", class 150 ... 600 	
Guide tube diameter	18 mm	
Max. guide tube length L	4,000 mm	
Float	Material: <ul style="list-style-type: none"> ■ Stainless steel 1.4571, ECTFE coated ■ PVDF ■ PTFE Float diameter: 44 ... 120 mm Float selection depending on guide tube diameter and process conditions (see page 15 and 16)	
Max. operating pressure	80 bar (see page 15 and 16)	
Temperature range	-20 ... +120 °C Option: <ul style="list-style-type: none"> ■ High-temperature version: +120 ... +200 °C ■ Low-temperature version: -80 ... -20 °C 	
Resolution	2.7 mm / 5.5 mm / 7.5 mm / 9 mm (depending on contact separation)	
Overall resistance of the measuring chain	Depending on length and separation	
Head-mounted transmitter	External transmitter	Head-mounted transmitter, see page 18
Output	3-wire potentiometer	4 ... 20 mA
Connection cable to transmitter / control room	Cable length max. 2,000 m, 3-wire, screened	2-wire, screened
Permissible power supply	< AC 50 V, < DC 75 V	See the data sheet of the head-mounted transmitter used
Mounting position	Vertical ±30°	
Ingress protection	up to IP66 or IP68 per IEC/EN 60529 (depending on version)	

Sensor, standard version with cable or plug connection Models FLR-SE, FLR-SF

Process connection, guide tube and float from stainless steel

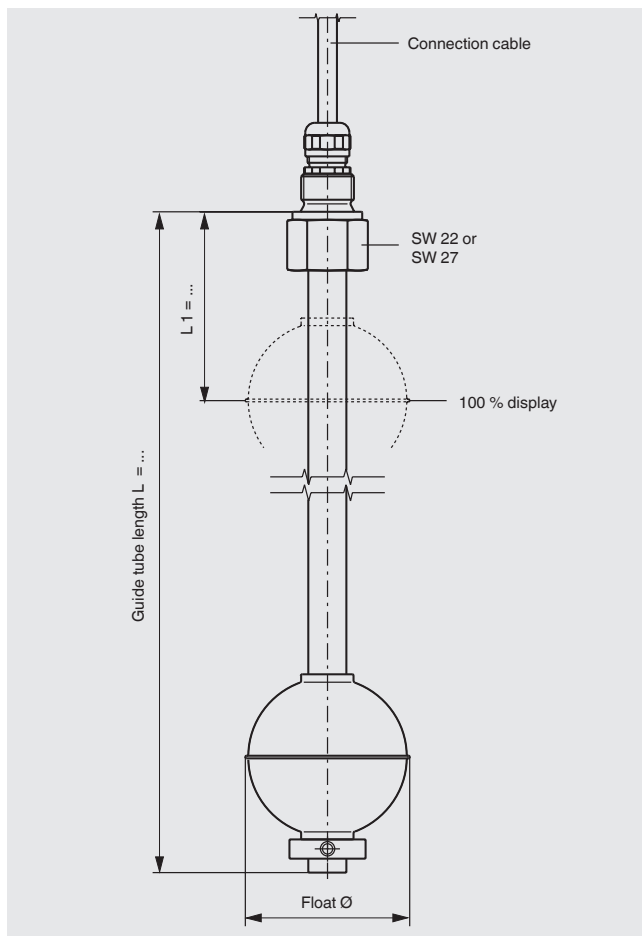

	Model FLR-SE	Model FLR-SF
Electrical connection	Connection cable ■ PVC ■ Silicone ■ PUR	Coupler connector ■ DIN 43650, 4-pin ■ M12, 4-pin
Process connection	Mounting thread upwards: G 3/8" or G 1/2" others on request	
Guide tube diameter	8 mm / 12 mm / 14 mm / 18 mm	
Max. guide tube length L	■ 500 mm (guide tube diameter 8 mm) ■ 3,000 mm (guide tube diameter 12 or 14 mm) ■ 6,000 mm (guide tube diameter 18 mm)	
Float	Material: Stainless steel 1.4571 (option: Buna, titanium) Float diameter: 44 ... 120 mm Float selection depending on guide tube diameter and process conditions (see page 15 and 16)	
Max. operating pressure	80 bar	
Temperature range	PVC/PUR cable -10 ... +80 °C Silicone cable -10 ... +120 °C	
Resolution	2.7 mm / 5.5 mm / 7.5 mm / 9 mm (depending on contact separation)	
Overall resistance of the measuring chain	Depending on length and separation	
Output	3-wire potentiometer	
Connection cable to transmitter	Cable length max. 2,000 m, 2-wire, screened	
Mounting position	Vertical ±30°	
Ingress protection	up to IP66 or IP68 per IEC/EN 60529 (depending on version)	

Sensor, plastic version with connection housing

Models FLR-PA, FLR-PB

Process connection, guide tube and float from polypropylene, PVDF or PVC

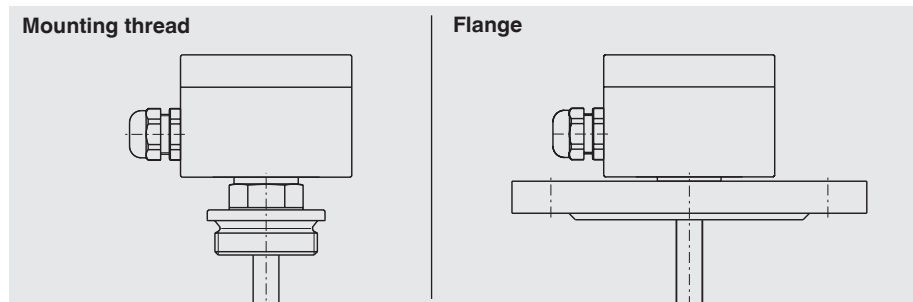
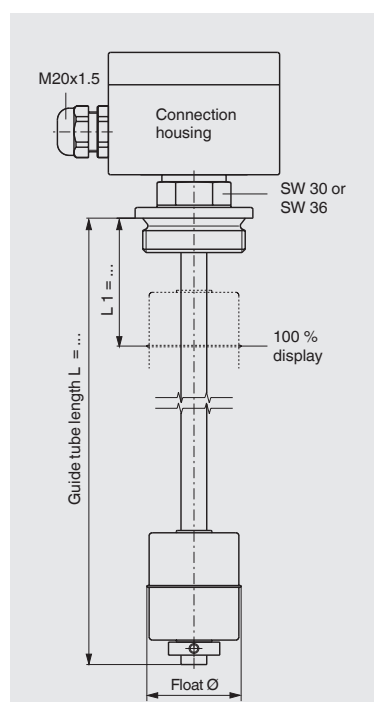

	Model FLR-PA	Model FLR-PB
Electrical connection	Connection housing: Polyester 80 x 75 x 57 mm	Connection housing: Polyester 80 x 75 x 57 mm with head-mounted transmitter
Process connection	<ul style="list-style-type: none"> ■ Mounting thread downwards G 2", others on request ■ Mounting flange - DIN DN 65 ... DN 125, PN 10, form A - ANSI 2 1/2" ... 5", class 150 FF 	
Guide tube diameter	16 or 20 mm (strengthened with a metallic inner tube)	
Max. guide tube length L	<ul style="list-style-type: none"> ■ 3,000 mm (guide tube diameter 16 mm) ■ 5,000 mm (guide tube diameter 20 mm) 	
Float	Material: Polypropylene, PVDF, PVC Float diameter: 44 ... 80 mm Float selection depending on guide tube diameter and process conditions (see page 15 and 16)	
Max. operating pressure	3 bar	
Temperature range	Polypropylene -10 ... +80 °C PVDF -10 ... +100 °C PVC 0 ... 60 °C	
Resolution	2.7 mm / 5.5 mm / 7.5 mm / 9 mm (depending on contact separation)	
Overall resistance of the measuring chain	Depending on length and separation	
Head-mounted transmitter	External transmitter	Head-mounted transmitter, see page 18
Output	3-wire potentiometer	4 ... 20 mA
Connection cable to transmitter / control room	Cable length max. 2,000 m, 3-wire, screened	2-wire, screened
Permissible power supply	< AC 50 V, < DC 75 V	See the data sheet of the head-mounted transmitter used
Mounting position	Vertical ±30°	
Ingress protection	up to IP66 or IP68 per IEC/EN 60529 (depending on version)	

Sensor, explosion-protected version Ex i, intrinsically safe Models FLR-SAI, FLR-SBI (NMG 125)



KEMA 01 ATEX 1052 X (II 1/2G Ex ia IIC T4 ... T6 Ga/Gb or II 2D Ex ib IIIC T80 °C Db)

Process connection, guide tube and float from stainless steel 1.4571

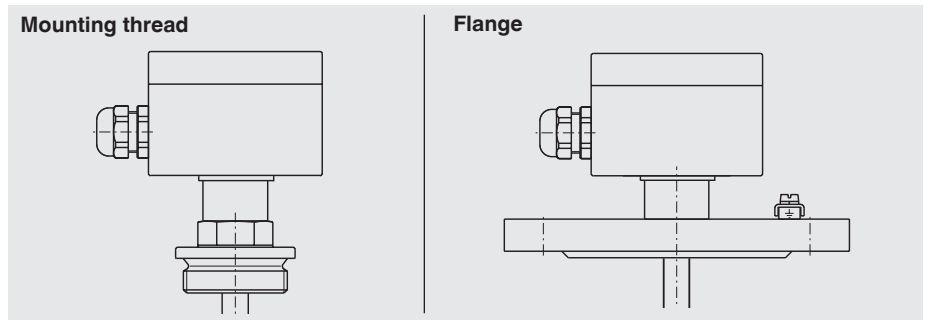
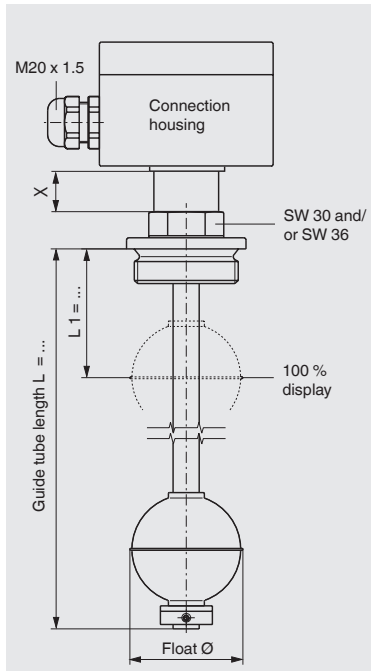

	Models FLR-SAI (NMG 125)	Model FLR-SBI (NMG 125)																
Electrical connection	Connection housing: Aluminium 80 x 75 x 57 mm Option: Stainless steel	Connection housing: Aluminium 80 x 75 x 57 mm with head-mounted transmitter Option: Stainless steel																
Process connection	<ul style="list-style-type: none"> ■ Mounting thread downwards G 1 1/2" or G 2", others on request ■ Mounting flange - DIN DN 50 ... DN 350, PN 6 ... PN 100 - ANSI 2" ... 8", class 150 ... 600 																	
Guide tube diameter	12 mm / 14 mm / 18 mm																	
Max. guide tube length L	see page 15 and 16																	
Float	Material: Stainless steel 1.4571 Float diameter: 44 ... 120 mm Float selection depending on guide tube diameter and process conditions (see page 15 and 16)																	
Max. operating pressure	see page 15 and 16																	
Temperature class	<table border="1" style="width: 100%; border-collapse: collapse;"> <thead> <tr> <th></th> <th>T4</th> <th>T5</th> <th>T6</th> </tr> </thead> <tbody> <tr> <td>■ Surface temperature</td> <td>Max. 135 °C</td> <td>100 °C</td> <td>85 °C</td> </tr> <tr> <td>■ Process temperature</td> <td>Max. 100 °C</td> <td>65 °C</td> <td>50 °C</td> </tr> <tr> <td>■ Ambient temperature at connection housing</td> <td>Max. 60 °C</td> <td>60 °C</td> <td>60 °C</td> </tr> </tbody> </table>			T4	T5	T6	■ Surface temperature	Max. 135 °C	100 °C	85 °C	■ Process temperature	Max. 100 °C	65 °C	50 °C	■ Ambient temperature at connection housing	Max. 60 °C	60 °C	60 °C
	T4	T5	T6															
■ Surface temperature	Max. 135 °C	100 °C	85 °C															
■ Process temperature	Max. 100 °C	65 °C	50 °C															
■ Ambient temperature at connection housing	Max. 60 °C	60 °C	60 °C															
Resolution	2.7 mm / 5.5 mm / 7.5 mm / 9 mm (depending on contact separation)																	
Overall resistance of the measuring chain	Depending on length and separation																	
Control circuit	Ignition protection type Ex ia IIC (only for connection to a certified intrinsically safe control circuit)																	
Transmitter	External transmitter with max. 120 mA, max. 28 V	Head-mounted transmitter in accordance with transmitter approvals, see page 18																
Output	3-wire potentiometer	4 ... 20 mA																
Connection cable to transmitter / control room (if head-mounted transmitter)	Cable length max. 2,000 m, 3-wire, screened	2-wire, screened																
Permissible power supply	< AC 50 V, < DC 75 V	See the data sheet of the head-mounted transmitter used																
Mounting position	Vertical ±30°																	
Ingress protection	up to IP66 or IP68 per IEC/EN 60529 (depending on version)																	

Sensor, explosion-protected version Ex d, flameproof enclosure Models FLR-SAD, FLR-SBD (AF-ADF)



TÜV 13 ATEX 7399 X (II 2G Ex d IIC T6 Gb / II 2 D Ex tb IIIC T80 °C Db)
IECEX TUR 09.0002X (-40 °C ≤ T_a ≤ +55 °C Ex d IIC T6 Ex tD A21 IP65 T80 °C)
Process connection, guide tube and float from stainless steel 1.4571

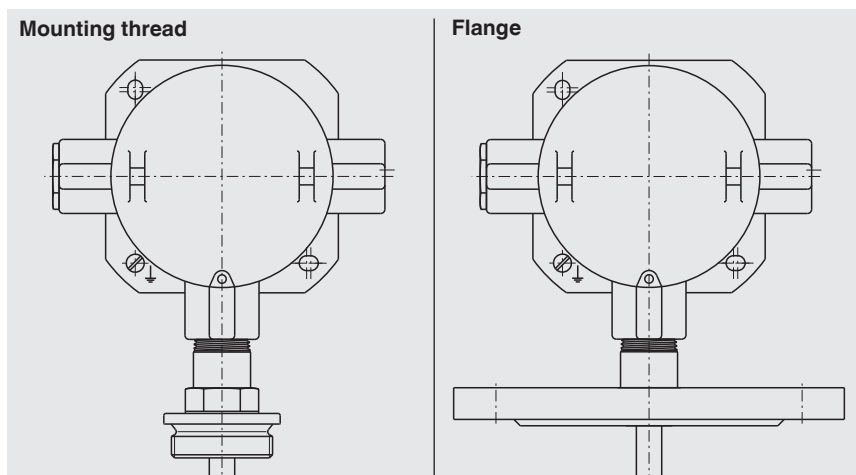
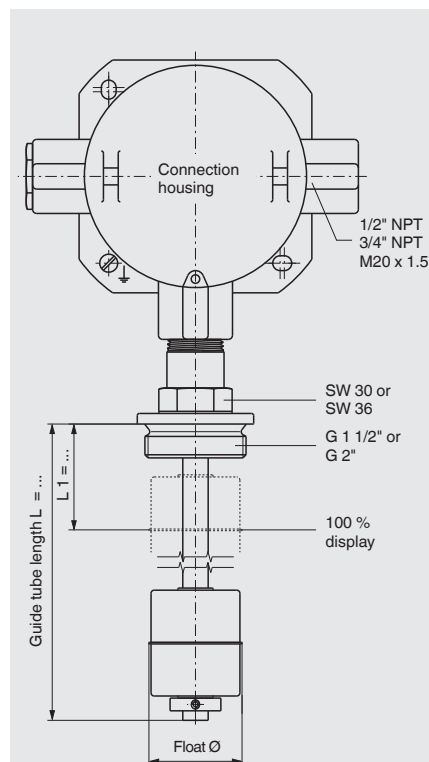

	Model FLR-SAD (AF-ADF)	Model FLR-SBD (AF-ADF)
Electrical connection	Connection housing: Aluminium 170 x 151 x 87 mm Option: Stainless steel	Connection housing: Aluminium with head-mounted transmitter Option: Stainless steel
Process connection	<ul style="list-style-type: none"> ■ Mounting thread downwards G 1 1/2" or G 2", others on request ■ Mounting flange <ul style="list-style-type: none"> - DIN DN 50 ... DN 350, PN 6 ... PN 40 - ANSI 2" ... 14", class 150 ... 300 	
Guide tube diameter	12 mm / 14 mm / 18 mm	
Max. guide tube length L	<ul style="list-style-type: none"> ■ 3,000 mm (guide tube diameter 12 or 14 mm) ■ 5,000 mm (guide tube diameter 18 mm) 	
Float	Material: Stainless steel 1.4571 Float diameter: 44 ... 120 mm Float selection depending on guide tube diameter and process conditions (see page 15 and 16)	
Max. operating pressure	see page 15 and 16	
Temperature class	T4: 120 °C, T5: 95 °C, T6: 80 °C	
Resolution	2.7 mm / 5.5 mm / 7.5 mm / 9 mm (depending on contact separation)	
Overall resistance of the measuring chain	Depending on length and separation	
Transmitter	External transmitter	Head-mounted transmitter, see page 18
Output	3-wire potentiometer	4 ... 20 mA
Connection cable to transmitter / control room (if head-mounted transmitter)	Cable length max. 2,000 m, 3-wire, screened	2-wire, screened
Permissible power supply	< AC 50 V, < DC 75 V	See the data sheet of the head-mounted transmitter used
Mounting position	Vertical ±30°	
Ingress protection	up to IP66 or IP68 per IEC/EN 60529 (depending on version)	

Sensor, plastic version with cable or plug connection Models FLR-PE, FLR-PF

Process connection, guide tube and float from polypropylene, PVDF or PVC

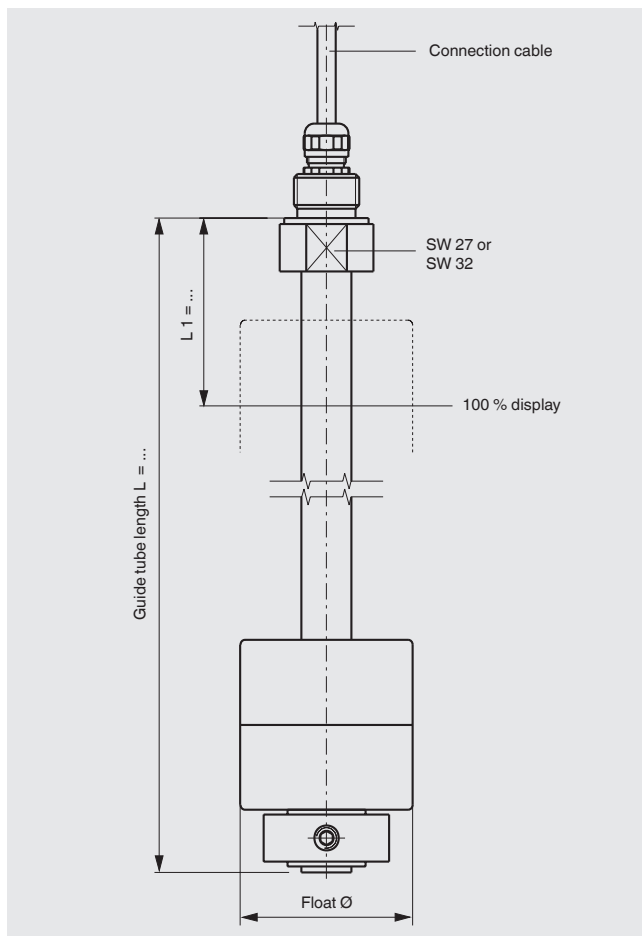

	Model FLR-PE	Model FLR-PF
Electrical connection	Connection cable ■ PVC ■ Silicone ■ PUR	Coupler connector ■ DIN 43650, 4-pin ■ M12, 4-pin
Process connection	Mounting thread upwards: ■ G ½" (guide tube diameter 16 mm) ■ G 1" (guide tube diameter 20 mm) others on request	
Guide tube diameter	16 or 20 mm (strengthened with a metallic inner tube)	
Max. guide tube length L	■ 3,000 mm (guide tube diameter 16 mm) ■ 5,000 mm (guide tube diameter 20 mm)	
Float	Material: Polypropylene, PVDF, PVC Float diameter: 55 ... 80 mm Float selection depending on guide tube diameter and process conditions (see page 15 and 16)	
Max. operating pressure	3 bar	
Temperature range	Polypropylene -10 ... +80 °C PVDF -10 ... +100 °C PVC 0 ... 60 °C	
Resolution	2.7 mm / 5.5 mm / 7.5 mm / 9 mm (depending on contact separation)	
Overall resistance of the measuring chain	Depending on length and separation	
Connection cable to transmitter	Cable length max. 2,000 m, 3-wire, screened	
Mounting position	Vertical ±30°	
Ingress protection	up to IP66 or IP68 per IEC/EN 60529 (depending on version)	

Sensor, sterile/food version with connection housing

Models FLR-HA, FLR-HB

Process connection, guide tube and float from stainless steel 1.4435 (316L) or 1.4404 (316L)

Surface ground and polished $R_a < 0.8 \mu\text{m}$ or $R_a < 0.4 \mu\text{m}$, alternatively electropolished

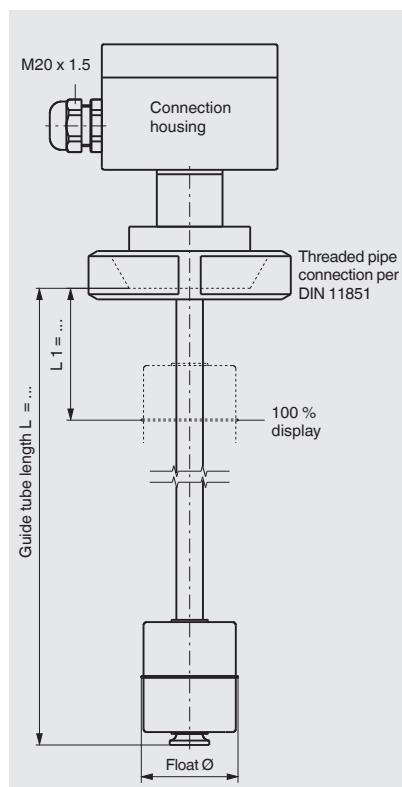

Threaded pipe connection per DIN 11854

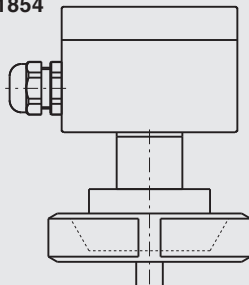

Clamp pipe connection per DIN 32676

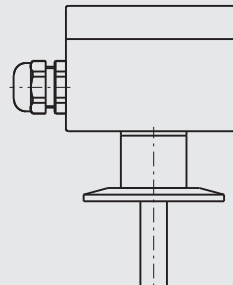

	Model FLR-HA	Model FLR-HB
Electrical connection	Connection housing: Aluminium 80 x 75 x 57 mm Option: Polypropylene, polyester, stainless steel	Connection housing: Aluminium 80 x 75 x 57 mm with head-mounted transmitter Option: Polypropylene, polyester, stainless steel
Process connection	<ul style="list-style-type: none"> ■ Threaded pipe connection per DIN 11851, downwards, DN 50 ... DN 150 ■ Clamp pipe connection DIN 32676, DN 25 ... DN 100 or 1" ... 4" others on request 	
Guide tube diameter	12 mm / 14 mm / 18 mm	
Max. guide tube length L	<ul style="list-style-type: none"> ■ 3,000 mm (guide tube diameter 12 or 14 mm) ■ 6,000 mm (guide tube diameter 18 mm) 	
Float	Material: Stainless steel 1.4435 or 1.4404, option electropolished Float diameter: 44 ... 120 mm Float selection depending on guide tube diameter and process conditions (see page 15 and 16)	
Max. operating pressure	see page 15 and 16	
Temperature range	-20 ... +120 °C Option: <ul style="list-style-type: none"> ■ High-temperature version: +120 ... +200 °C ■ Low-temperature version: -80 ... -20 °C 	
Resolution	2.7 mm / 5.5 mm / 7.5 mm / 9 mm ¹⁾ (depending on contact separation)	
Overall resistance of the measuring chain	Depending on length and separation	
Head-mounted transmitter	External transmitter	Head-mounted transmitter, see page 18
Output	3-wire potentiometer	4 ... 20 mA
Connection cable to transmitter / control room	Cable length max. 2,000 m, 3-wire, screened	2-wire, screened
Permissible power supply	< AC 50 V, < DC 75 V	See the data sheet of the head-mounted transmitter used
Mounting position	Vertical ±30°	
Ingress protection	up to IP66 or IP68 per IEC/EN 60529 (depending on version)	

1) Not with high- and low-temperature version

Sensor, sterile version (3-A) with connection housing Models FLR-HA3, FLR-HB3



Process connection, guide tube and float from stainless steel 1.4435 (316L) or 1.4404 (316L), surface ground and polished $R_a < 0.8 \mu\text{m}$ or $R_a < 0.4 \mu\text{m}$, alternatively electropolished

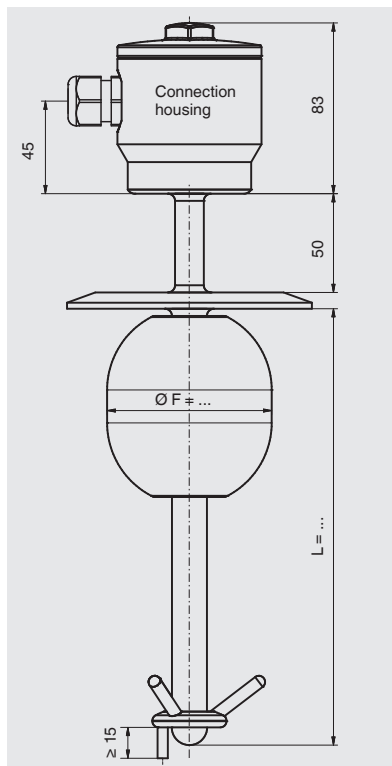

With welded tube end

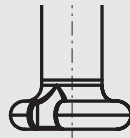

With separate float bracket

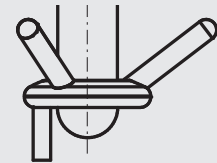

	Model FLR-HA3	Model FLR-HB3
Electrical connection	Connection housing: Stainless steel 1.4571 with threaded connection M20 x 1.5 (polyamide or hygienic design)	Connection housing: Aluminium with head-mounted transmitter Option: Polypropylene, polyester, stainless steel
Process connection	<ul style="list-style-type: none"> ■ Clamp pipe connection ISO 2852, DN 32 ... DN 100 or 1.5" ... 4" ■ Clamp pipe connection DIN 32676, DN 32 ... DN 100 or 1.5" ... 4" ■ Aseptic mounting thread downwards DIN 11864-1, DN 32 ... DN 100 or 1.5" ... 4" ■ Aseptic liner DIN 11864-1, DN 32 ... DN 100 or 1.5" ... 4" ■ Aseptic flange connection DIN 11864-2 (DN 32 ... DN 50 or 1.5" ... 2" ■ Aseptic clamp connection DIN 11864-3, DN 32 ... DN 100 or 1.5" ... 4" ■ VARIVENT® (form F, N and G) ■ BioConnect® threaded connection, DN 32 ... DN 100 or 1,5" ... 2" ■ BioConnect® flange connection, DN 32 ... DN 100 or 1.5" ... 2" ■ BioConnect® clamp connection, DN 32 ... DN 100 or 1.5" ... 4" 	
Guide tube diameter	12 mm / 14 mm / 17.2 mm (stainless steel 1.4435 or 1.4404, surface ground or polished, $R_a < 0.8 \mu\text{m}$)	
Max. guide tube length L	6,000 mm	
Float	Material: Stainless steel 1.4435 or 1.4404 Float diameter: 50 ... 80 mm Float selection depending on guide tube diameter	
Max. operating pressure	10 bar	
Temperature range	Medium standard: -40 ... +200 °C	Sensor housing: -40 ... +85 °C
Resolution	2.7 mm / 5.5 mm / 7.5 mm / 9 mm (depending on contact separation)	
Overall resistance of the measuring chain	Depending on length and separation	
Head-mounted transmitter	External transmitter	Head-mounted transmitter, see page 18
Output	3-wire potentiometer	4 ... 20 mA
Connection cable to transmitter / control room (if head-mounted transmitter)	Cable length max. 2,000 m, 3-wire, screened	2-wire, screened
Permissible power supply	< AC 50 V, < DC 75 V	See the data sheet of the head-mounted transmitter used
Mounting position	Vertical $\pm 30^\circ$	
Ingress protection	up to IP66 or IP68 per IEC/EN 60529 (depending on version)	

Determination of the max. guide tube length L for explosion-protected version, intrinsically safe

Version A: Fixed to the tank ceiling

Version B: Fixed to the tank ceiling and floor

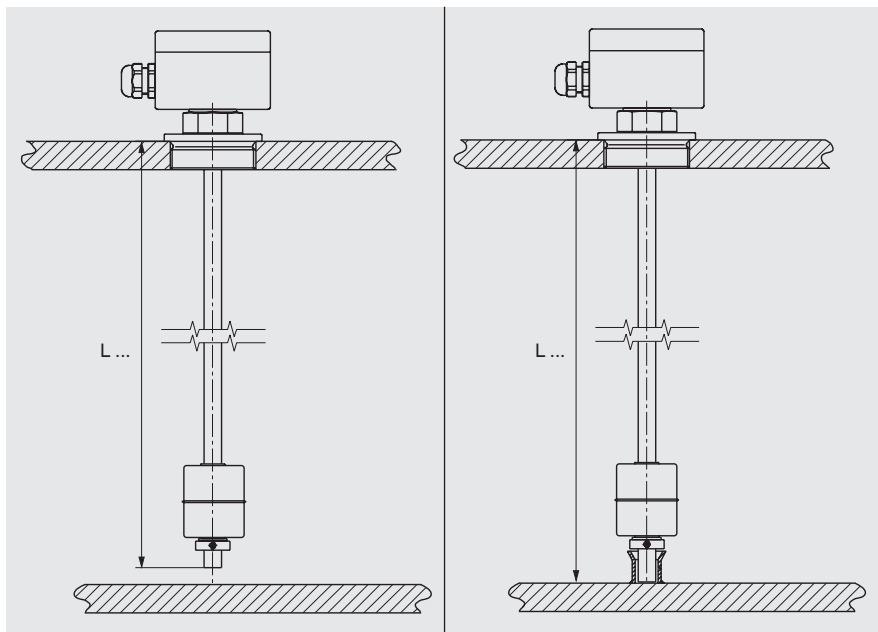

Guide tube	Max. guide tube length L	
	Version A	Version B
Ø 12 x 1	660 mm	3,500 mm
Ø 14 x 1	940 mm	5,000 mm
Ø 14 x 2	1,600 mm	6,000 mm
Ø 18 x 2	3,000 mm	6,500 mm

Illustration with the required dimensions for ordering

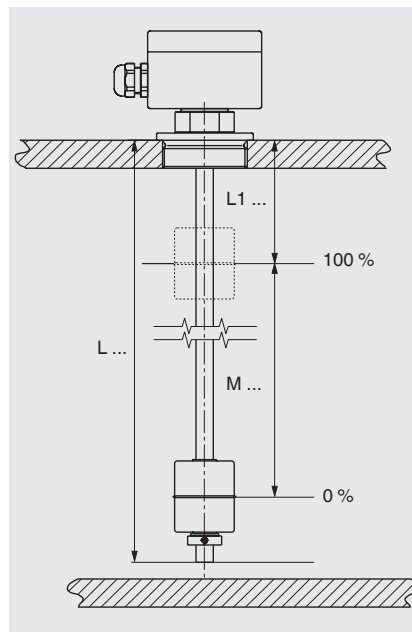

Legend

L_1 = 100 % mark (distance sealing face-float centre)

M = Measuring range (distance 0 ... 100 %)

L = Guide tube length and/or insertion length of the sensor

On ordering, the dimension L_1 and the guide tube length (immersion length) L must be given.

Subsequent alteration of the measuring range is not possible.

Spherical float

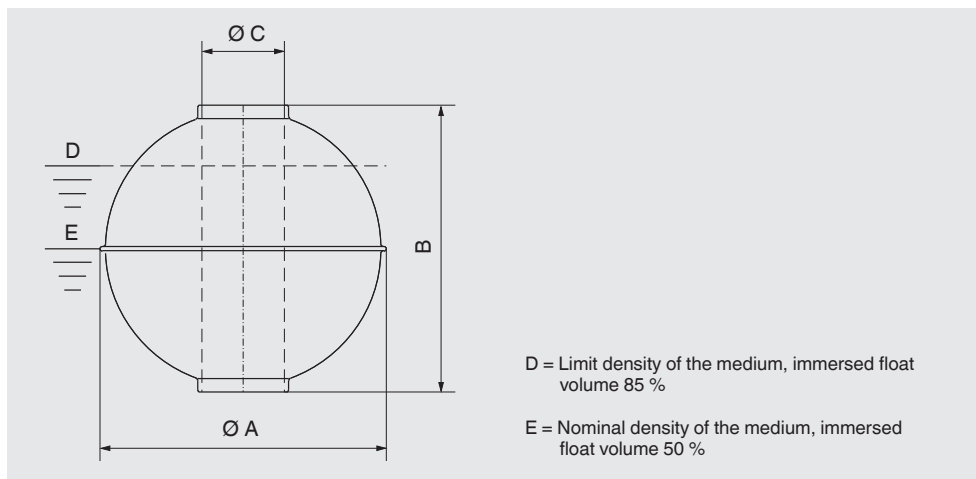

Material	Version	Suits guide tube Ø in mm	Ø A in mm	B in mm	Ø C in mm	Max. operating pressure in bar	Max. operating temp. in °C	Limit density 85 % in kg/m ³	Order no.
Stainless steel	V52R	12	52	52	15	40	250	700	020913
	V62R	12	62	61	15	32	250	670	026026
	V83R	12	83	81	15	25	250	430	021089
	V80R	18	80	76	23	25	250	630	005479
	V98R	18	98	96	23	25	250	600	005490
	V105R	18	105	103	23	25	250	560	005494
	V120R	18	120	117	23	25	250	390	026726
	V120R	18 ... 30	120	116	38	25	250	537	-
	V200R	18 ... 30	200	192	56	16	250	581	005503
	V300R	18 ... 30	300	294	56	16	250	342	-
Titanium 3.7035	T52R	12	52	52	15	25	250	680	-
	T52R	12	52	52	15	60	250	810	-
	T52R	12	52	52	15	80	250	997	-
	T62R	12	62	62	15	25	250	390	005538
	T83R	12	83	81	15	25	250	350	005544
	T80R	18	80	76	23	25	250	670	005543
	T98R	18	98	96	23	25	250	536	-
	T105R	18	105	103	23	25	250	440	005549
	T120R	18	120	117	23	25	250	315	115002
Stainless steel 1.4571 ECTFE coated	VEC81R	18	81	77	22	25	Depending on medium	634	-
	VEC99R	18	99	97	22	25	Depending on medium	653	-
	VEC106R	18	106	104	22	25	Depending on medium	595	-
	VEC121R	18	121	118	22	3	Depending on medium	435	-

Cylindrical float

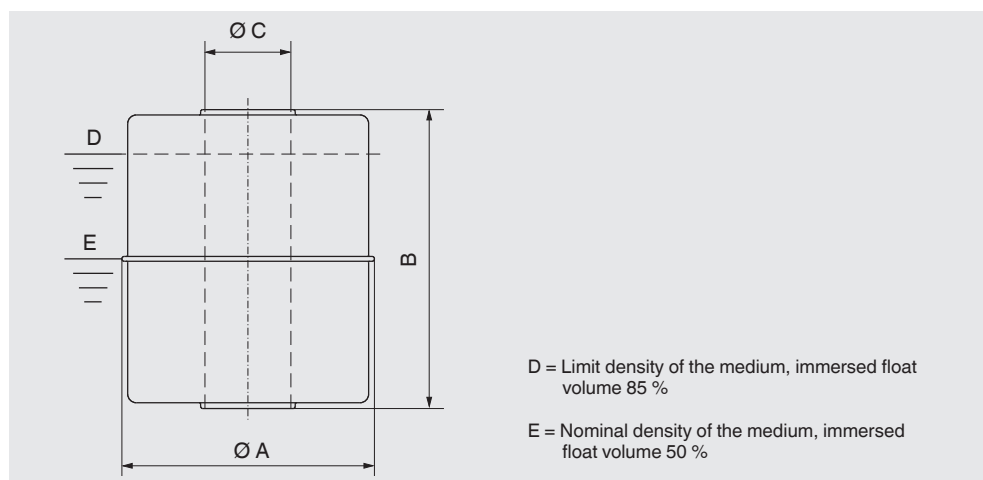

Material	Version	Suits guide tube Ø in mm	Ø A in mm	B in mm	Ø C in mm	Max. operating pressure in bar	Max. operating temp. in °C	Limit density 85 % in kg/m ³	Order no.
Stainless steel 1.4571	V44R	12	44	52	15	16	250	740	034196
Titanium 3.7035	T44R	12	44	52	15	16	250	550	022639
PVC	P55R	16	55	54	22	3	60	805	033696
	P80R	20	80	79	25	3	60	577	033697
Polypropylene	PP55R	16	55	54	22	3	80	592	033700
	PP80R	20	80	79	25	3	80	438	033701
PVDF	PF55R	16	55	69	22	3	100	809	033698
	PF80R	20	80	79	25	3	100	706	033699

Hygienic float

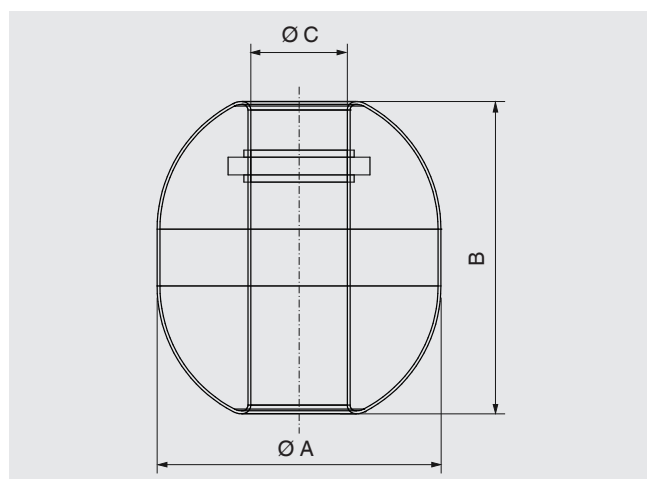

Material	Model	Version	Suits guide tube Ø in mm	Ø A in mm	B in mm	Ø C in mm	Max. operating pressure in bar	Max. operating temp. in °C	Limit density 85 % in kg/m ³	Order no.
Stainless steel 1.4435	V80/88/R2/3A/35 radial	V80R	18	80	55	23	116	250	800	025984
	V50/55/17/A34/3A/35	V50A	12	50	55	16.8	16	250	1,100	026400
	V55/70/A34/3A/35 axial	V55A	12	55	70	17	16	250	900	122064

Application examples

Standard applications

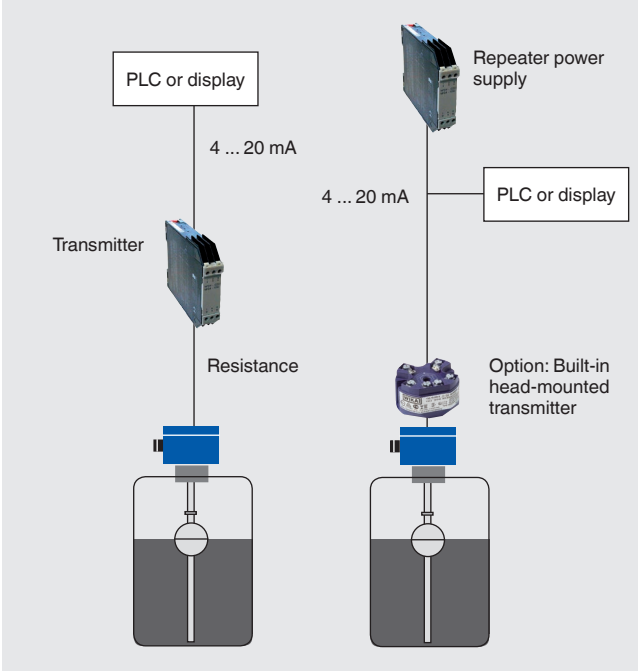

Connection to bus systems

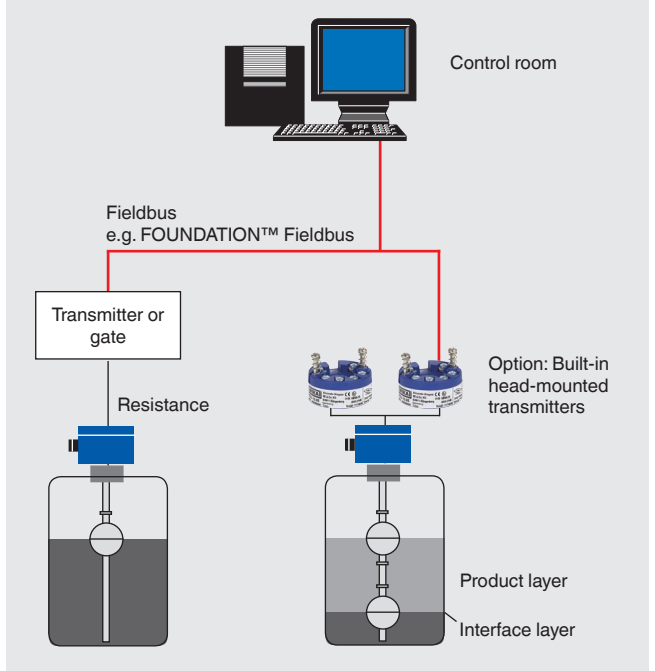

Applications for Ex-Zone 0

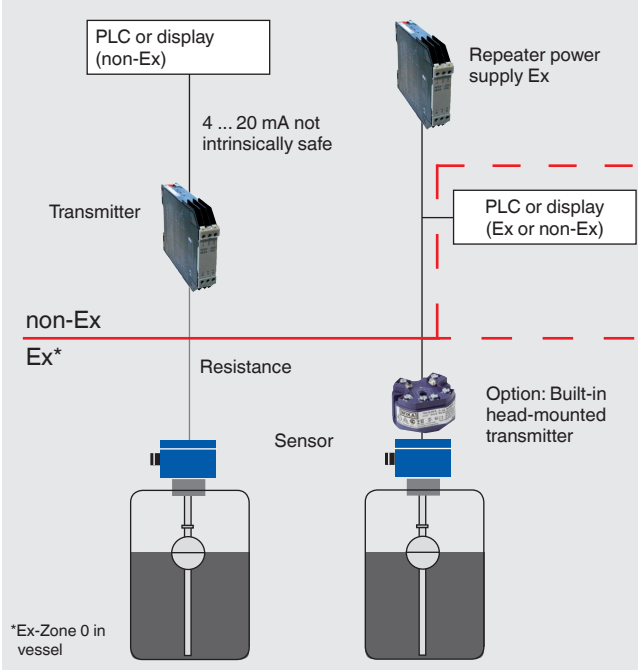

Applications for Ex zone 1, 2

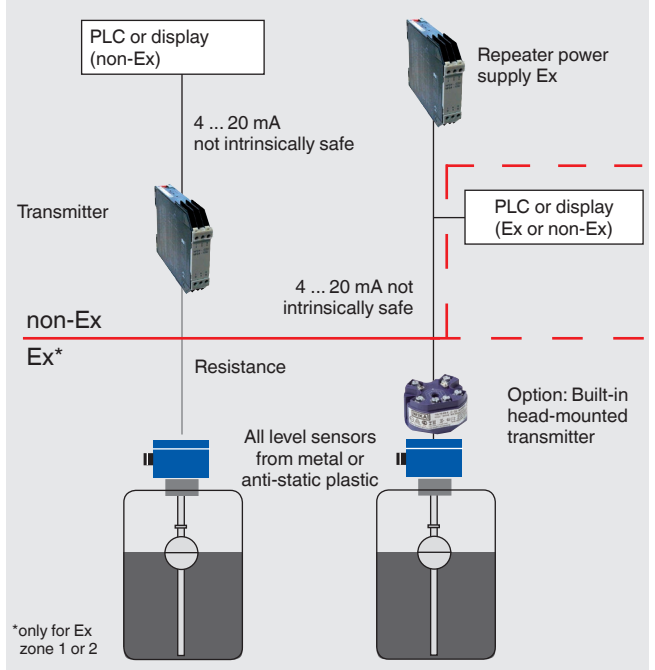

Head-mounted transmitter

Model T15



Model T32



Model T53



Model TLEH



Model	4 ... 20 mA	HART®	PROFIBUS® PA	FOUNDATION™ Fieldbus	Ex i	Display	Order no.
TE	x				x		014832
TS	x						005894
T32E	x	x			x		025216
T32S	x	x					114795
T53F				x	x		025727
T53P			x		x		034422
TLH	x	x				x	019989
TLEH	x	x			x	x	021104
T15	x				x		122955 122954

Ordering information

Model / Version / Electrical connection / Process connection / Guide tube diameter / Guide tube length (insertion length) L / Contact separation / 100 % mark L1 / Measuring range M (span 0 ... 100 %) / Process specifications (operating temperature and pressure, limit density) / Options

To order the described floats and head-mounted transmitters the order number is sufficient.

© 02/2010 WIKA Alexander Wiegand SE & Co. KG, all rights reserved.
The specifications given in this document represent the state of engineering at the time of publishing.
We reserve the right to make modifications to the specifications and materials.



WIKAI Alexander Wiegand SE & Co. KG
Alexander-Wiegand-Straße 30
63911 Klingenberg/Germany
Tel. +49 9372 132-0
Fax +49 9372 132-406
info@wika.de
www.wika.de