



Masoneilan

Putting You In Control

Specification Data

CP72000

02/10



72000 Series

Large Mass Flow
Energy Management
Control Valves





Dresser Masoneilan 72000 Series

Large Mass Flow
Energy Management
Control Valves

Table of Contents

Introduction	3	Hydrocarbon Service Material Options	10
Product Features	3	Steam Service Material Options	11
General Data	5	Selection Instructions	12
Numbering System	6	Typical Dimensions	12
Temperature Range / Seat Leakage	6	Approximate Shipping Weights	13
Rated C_v Table	7	Accessories and Options	13
General Arrangement and Parts Description	8		

Introduction

Masoneilan's® 72000 Series energy management and low noise products are specifically designed for applications with large mass flow rates and high differential pressures. Typical installations may be found in compressor surge control, gas to flare, atmospheric vent, or other applications where the ratio of inlet/outlet pressures require substantial levels of noise attenuation and large valve sizes. A variety of options and configurations are available to create effective solutions for our customers' specific applications.

The 72000 Series is a valve solution engineered to meet a client's need. As such, the exact product configuration may differ from the general specifications, dependent upon the application. For additional information contact your local Masoneilan Sales representative.

The 72000 Series Control Valve may be custom engineered to fit an application. The data within this catalog is representative of typical configurations and does not include all potential design options.

Product Features

Engineered – Best Fit – Solutions

At Masoneilan we believe our customers deserve the Best Fit solution for their severe service valve applications. Our broad product portfolio and valve trim technologies allow an uncompromising approach in addressing a client's need, and therefore, each 72000 Series valve is engineered to meet a customer's exact specifications and application conditions. This allows us to offer the most technically advanced and cost-effective solution to your energy management and noise control applications.

Low Noise Trim

The Masoneilan Best Fit approach allows for the widest range of noise attenuation options, providing the desired noise level at the lowest cost of ownership. These attenuation products range from single and double stage Lo-dB® trim or up to as many as 40 stages of 3-dimensional V-LOG® tortuous path trim. The selected trim option is always custom engineered to provide best results for each unique application.

Single and double stage Lo-dB trim is selected in most low to moderate pressure drop ratio applications. This technology is customized by modifying the size and spacing of each hole drilled into the cage to provide a minimal sound pressure level at the trim exit.

The 3-dimensional tortuous path design of Masoneilan's V-LOG trim controls pressure reduction through the management of the process fluid energy. This is accomplished by directing the gas through discrete flow channels that are designed with multiple stages consisting of 90-degree turns along with the intermediate contractions and expansions in the flow area. The enhanced flow geometry of the V-LOG trim creates a series of kinetic energy losses, followed by partial energy recoveries at each stage. This gradual letdown process is highly effective for noise attenuation due to the staged reduction of the fluid's pressure.

Large Pressure Drop – Energy Management

Process applications that require the 72000 Series design often experience extremely high pressure drop ratios (P_1/P_2). These high ratios release large amounts of energy as the process fluid's pressure is reduced. This energy release can lead to excessive noise and vibration if not properly addressed in the valve design.

The 3-dimensional tortuous path design of Masoneilan's V-LOG® Trim controls pressure reduction through the management of process fluid energy. This is accomplished by directing the gas through discrete flow channels.

Product Features (cont.)

The labyrinth flow path of the V-LOG Trim subjects the gas to a high level of friction as it is redirected through each turn in the flow path. V-LOG's patented flow contractions produce maximum flow resistance.

The enhanced flow geometry of the V-LOG trim creates a series of kinetic energy losses, followed by partial energy recoveries at each state. This gradual letdown process is highly effective for noise attenuation due to the staged reduction of the fluid pressure.

Each stage of the V-LOG trim is designed with an expansion in flow area, which is essential for managing fluid velocity that would otherwise increase as the pressure is reduced across each stage. The expanding area is designed to compensate for the volumetric expansion of the gas, preventing any increase in the kinetic energy as the pressure is reduced.

Trim velocity control is important for maintaining low aerodynamic noise levels within the valve body and trim. High velocity trim exit flow will yield high magnitude sound waves, which lead to valve body vibration in high-pressure letdown applications.

As a gas experiences a large reduction in pressure, the volume of the gas expands. This phenomenon will yield a higher downstream velocity if the piping is designed without considering this volumetric expansion. Masoneilan's 72000 Series is designed with expanded outlet areas to accommodate this expansion, and minimize the overall system noise level.

** Masoneilan considers both outlet mach number and the outlet expansion ratio for system noise calculation, per the IEC International Noise Predication Standard (IEC-60534-8-3).*

High Capacity

Masoneilan has developed flexible, automated design tools for the 72000 Series line, allowing "ground up" fabrication of custom engineered valve solutions in very short lead times. High capacities and custom C_v s are met through a wide range of valve plug diameters, stroke lengths, and body gallery diameters to suit any application within standard product lead times.

Balanced Plug

Balanced plug designs deliver stability with smaller actuator thrust requirements, as compared to unbalanced designs. Normally, the 72000 Series valves are installed in a flow-to-open configuration allowing radial expansion from the smaller diameter cage to the expanded area of the valve body. The free expansion of the fluid and precise separation of the trim exit flow jets, maximize trim noise attenuation and minimizes vibration within the valve body. For installations that require flow-to-close configurations, an auxiliary pilot plug may be supplied to reduce actuator thrust requirements.

Ease of Maintenance

Top entry trim allows easy access to the valve internals for lower life cycle costs and easier maintenance activity. Masoneilan provides ample padeyes and tapped holes for standard lifting and handling equipment, eliminating the need for special fixtures or tooling. All trim components are cage guided, with ample clearance at the body, bonnet, and bridge regions for ease of removal and replacement. The 72000 Series design employs a minimum number of gaskets and soft goods, making outage planning and stocking requirements easier.

General Data

Operating Data

■ Flow Direction

Flow to Open (Standard)

Flow to Close (Auxiliary Pilot Plug Option Only)

■ Flow Direction

Flow-to-Open (Standard)

Flow-to-Close (Optional)

■ Construction

Body, Bonnet & Bonnet Flange; Fabricated or Cast

Styles: Angle (Figures 1, 2, and 3)

Materials: Body

Carbon Steel

Low Temperature Carbon Steel

316 Stainless Steel

Chrome Moly Steels

Other materials available on request

Sizes: Inlet 4" – 30" (DN 100-750)

Outlet 6" – 36" (DN 150-900)

Larger sizes available on request

Connections:

End Types

ANSI Flanges

Printed or Through Bolted

RTJ Flanges

Printed or Through Bolted

Buttweld

API

Pressure Rating:

Inlet Ratings: ANSI Class 150# – 2500#

Outlet Ratings: ANSI Class 150# – 600#

Others available upon request

■ Trim

Plug:

Balanced

Unbalanced

Auxiliary Pilot

Cage or Stack:

Ported Cage

Single Stage Lo-dB

Double Stage Lo-dB

V-LOG Stack

Partial Stack

Seat Ring:

Quick Change

Numbering System

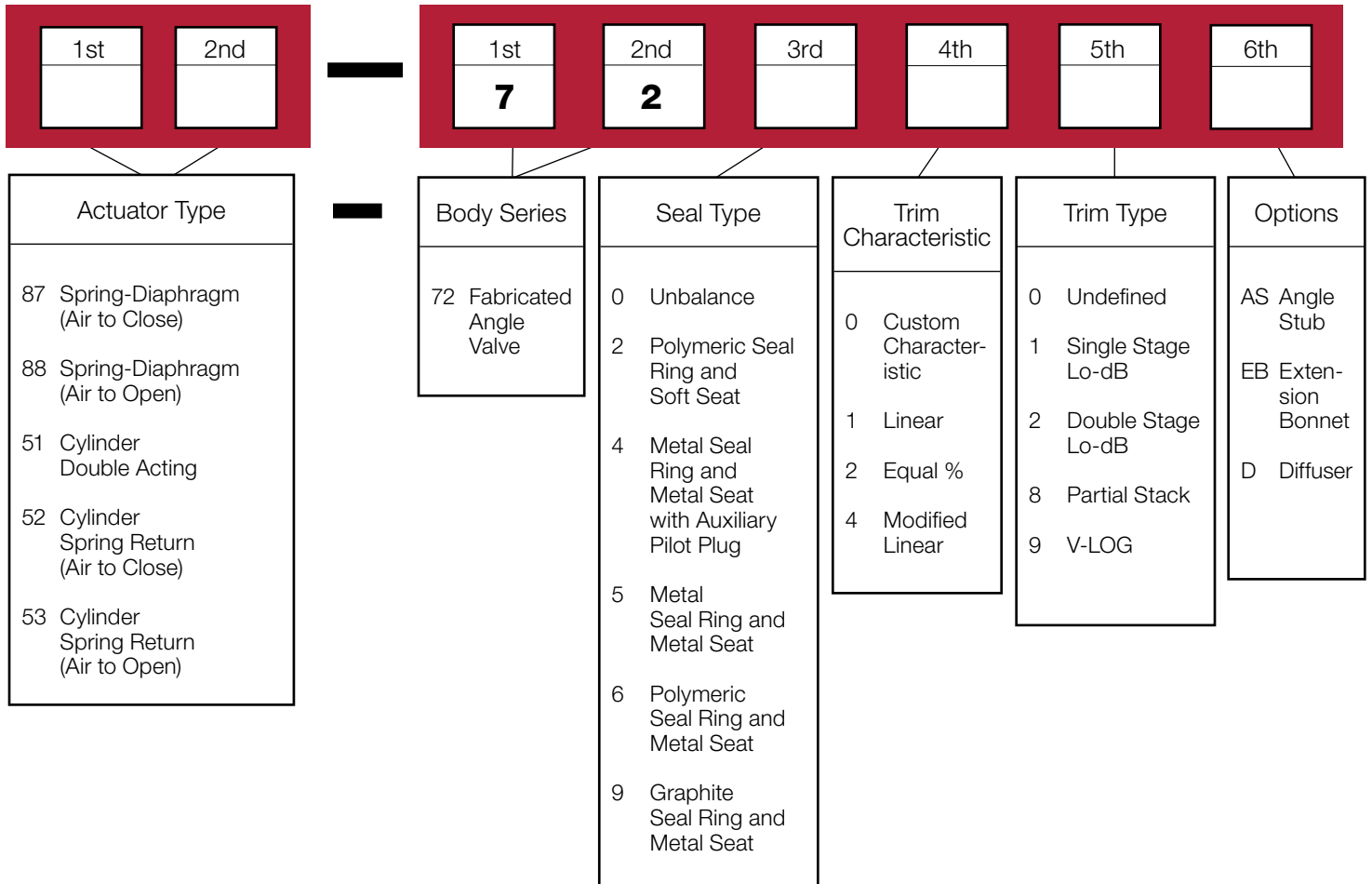

Temperature Range / Seat Leakage

Seal Ring	Seat Ring	Leakage Class	Temperature Ranges ⁽¹⁾	
			Min.	Max.
Unbalance	Metal	Class V MSS-SP-61	-320°F (-196°C)	1100°F (594°C)
Polymeric (Pressure Energized)	Filled PTFE	Class IV, V, VI	-50°F (-46°C)	450°F (232°C)
Pilot Plug	Metal	Class V	-320°F (-196°C)	1100°F (594°C)
Metal	Metal	Class III	-320°F (-196°C)	1100°F (594°C)
Polymeric (Pressure Energized)	Metal	Class IV,V MSS-SP-61	-50°F (-46°C)	450°F (232°C)
Graphite	Metal	Class III,IV	-320°F (-196°C)	850°F (454°C)

1. Cryogenic and high temp construction available, consult factory.

Flow Capacity

Rated C_v

Approximate C_v values are intended for estimation only. The actual C_v values will vary depending on the number of turns, stroke length, and resistance factor of each valve design. The specific C_v values will be determined by a Masoneilan engineer.

Size (Inch)	V-LOG # of Turns				Single Stage Lo-dB	Double Stage Lo-dB
	8	16	24	36		
4 x 6	100	70	38	25	200	110
4 x 8	140	98	53	35	265	140
4 x 10	175	125	66	44	300	165
6 x 6	220	154	84	55	320	175
6 x 8	275	192	105	68	425	225
6 x 10	325	230	125	80	500	275
8 x 8	450	315	170	112	575	310
8 x 10	525	368	200	130	650	350
8 x 12	550	385	210	138	900	500
10 x 10	600	420	230	150	850	475
10 x 16	660	462	250	165	1000	550
10 x 18	700	490	266	175	1200	680
10 x 20	730	510	278	182	1750	970
12 x 12	1050	735	400	260	1100	600
12 x 16	1200	840	460	300	1200	680
12 x 18	1280	900	485	320	1350	720
12 x 20	1320	920	500	330	1600	880
12 x 24	1350	945	510	338	2250	1250
16 x 16	1400	980	532	350	1750	950
16 x 20	1525	1065	580	380	2250	1250
16 x 24	1600	1120	608	400	2800	1520
16 x 30	1650	1155	627	410	3500	1930
20 x 20	1600	1120	610	400	2500	1380
20 x 24	1800	1260	685	450	2750	1520
20 x 30	1950	1365	740	485	3700	2000
20 x 36	2100	1470	800	525	5000	2750
24 x 24	2150	1500	820	540	3500	1930
24 x 30	2400	1680	910	600	4500	2500
24 x 36	2500	1750	950	625	6400	3500
30 x 30	3000	2100	1140	750	9400	5000
30 x 36	3600	2520	1370	900	13500	7000

These values represent typical construction. Larger or reduced capacity available upon request, consult factory.

Minimum Controllable C_v

Plug (Inch)	V-LOG # of Turns				Single Stage Lo-dB	Double Stage Lo-dB
	8	16	24	36		
4	2	1.5	0.8	0.6	4	3
6	4	3	2.5	2.2	8	7
8	6	5	3.6	3	15	12
10	9	6	4.7	4	30	25
12	15	12	9	7	40	35
16	20	14	11	8	70	60
20	25	18	14	11	90	75
24	40	26	20	14	120	105
30	60	40	25	18	250	215

These values represent typical construction. Higher rangeability available upon request, consult factory.

General Arrangement and Parts Description

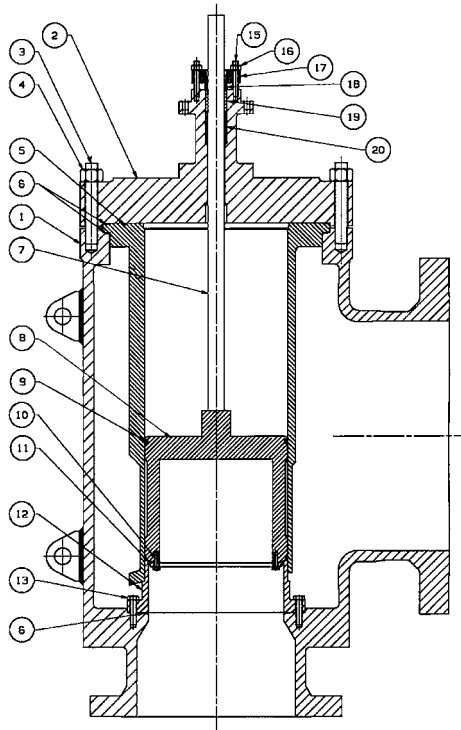

Figure 1 – Hung Cage Construction

Ref. No.	Description
1	Body
2	Bonnet
3	Body Stud
4	Body Nut
5	Hung Cage
•6	Gasket
7	Stem
8	Plug
9	Seal Ring
10	Cap Screw
11	Soft Seat
12	Seat Ring
13	Seat Ring Cap Screw
15	Packing Flange Stud
16	Packing Flange Nut
17	Packing Flange
18	Packing Follower
•19	Packing S/A
20	Guide Bushing

• Recommended Spare Parts

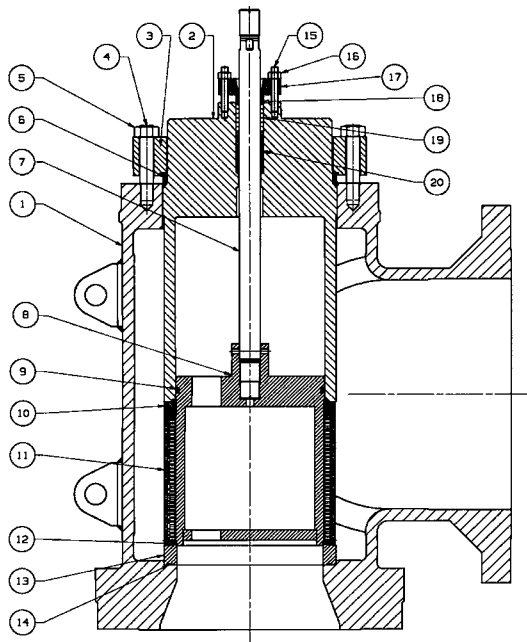
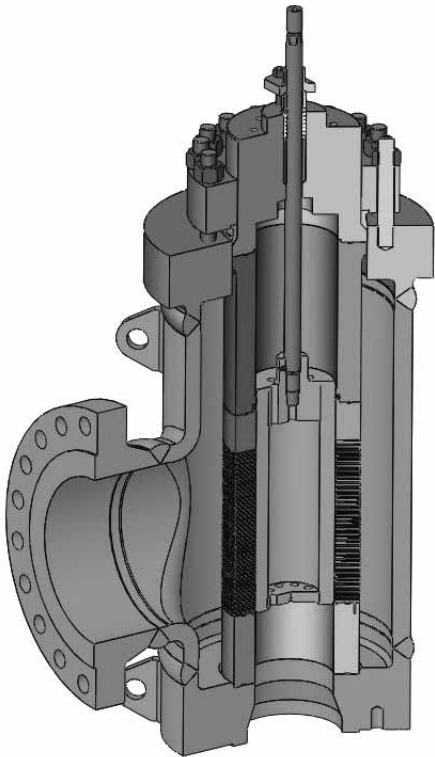

Figure 2 – High Pressure, Lo-dB
(Double Stage Option Shown)

Ref. No.	Description
1	Body
2	Bonnet
3	Bonnet Flange
4	Body Stud
5	Body Nut
6	Metal Seal
7	Stem
8	Plug
9	Seal Ring
10	Inner Cage
11	Outer Cage
12	Soft Seat
13	Seat Ring
•14	Gasket
15	Packing Flange Stud
16	Packing Flange Nut
17	Packing Flange
18	Packing Follower
•19	Packing S/A
20	Guide Bushing

• Recommended Spare Parts

General Arrangement and Parts Description



Cut Away View of Angle Style Valve with V-LOG Trim

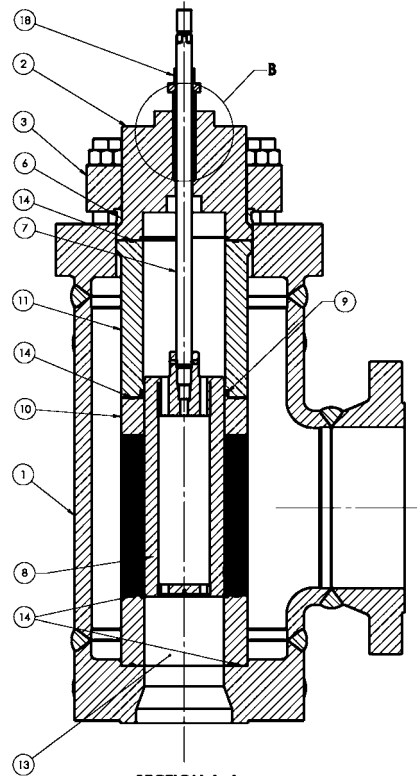

SECTION A-A

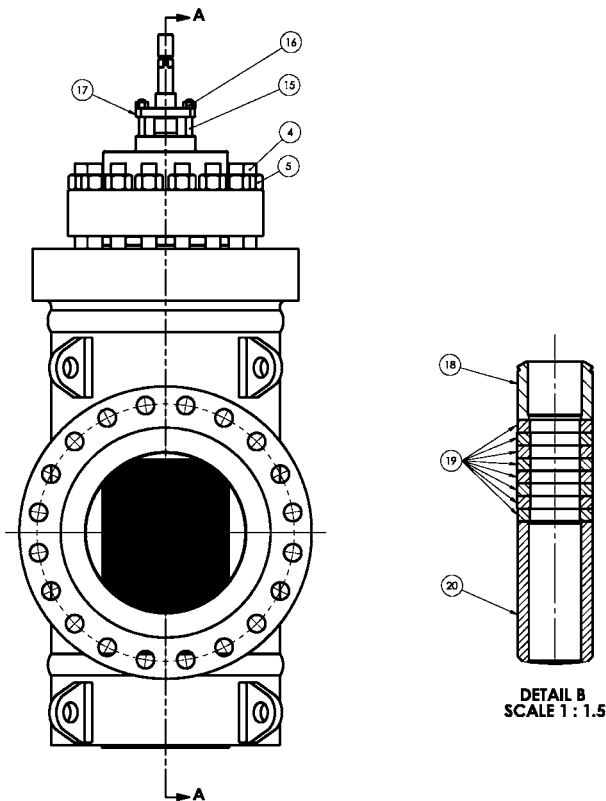

Figure 3 – V-LOG Construction

Ref. No.	Description
1	Body
2	Bonnet
3	Bonnet Flange
4	Body Stud
5	Body Nut
6	Metal Seal
7	Stem
8	Plug
9	Seal Ring S/A
10	V-Log Restrictor
11	Cage Retainer
13	Seat Ring
•14	Gasket
15	Packing Flange Stud
16	Packing Flange Nut
17	Packing Flange
18	Packing Follower
•19	Packing S/A
20	Guide Bushing

• Recommended Spare Parts

Hydrocarbon Service Material Options

Ref. No	Temperature Range	-20°F	-450°F	-650°F
		-29°C	-232°C	-343°C
Description		Standard and Optional Materials		
1	Body	Carbon Steel		
		300 Series Stainless Steel		
2	Bonnet	Carbon Steel		
		300 Series Stainless Steel		
3	Bonnet Flange	Carbon Steel		
		300 Series Stainless Steel		
4	Body Stud	Alloy Steel ASTM A193 Gr B7 ⁽¹⁾		
		Alloy Steel ASTM A193 Gr B7M ⁽²⁾		
5	Body Nut	Alloy Steel ASTM A194 Gr 2H ⁽¹⁾		
		Alloy Steel ASTM A194 Gr 2HM ⁽²⁾		
6	Metal Seal	Alloy Steel		
7	Stem	17-4 PH Condition H-1150M ⁽³⁾		
		Nitronic [®] 50 ⁽³⁾		
8	Plug	316 Stainless Steel / Chrome Plated and Hardfaced ⁽³⁾		
9	Seal Ring Sub-Assembly	PTFE + 25% Graphite and ELGILOY [®] Spring	Graphite	
10	Cage	316 Stainless Steel ⁽³⁾		
11	Cage Retainer	316 Stainless Steel ⁽³⁾		
13	Seat Ring	316 Stainless Steel with Hardfaced Seat ⁽³⁾		
14	Gasket	316 Stainless Steel with Flexible Graphite Filler (Spiral Wound)		
15	Packing Flange Stud	304 Stainless Steel ASTM A193 Gr B8 Class 2 ⁽¹⁾		
		Alloy Steel ASTM A193 Gr B7M ⁽²⁾		
16	Packing Flange Nut	304 Stainless Steel ASTM A194 Gr 8 ⁽¹⁾		
		Alloy Steel ASTM A194 Gr 2HM ⁽²⁾		
17	Packing Flange	300 Series Stainless Steel		
18	Packing Follower	300 Series Stainless Steel		
19	Packing Sub-Assembly	Teflon [®] V-Ring	Flexible Graphite	
20	Guide Bushing	RTFE	Stellite [®] 6 UNS 30006	

- Notes:
1. Materials designated for these parts conform to NACE MR0103 Class III bolting requirements.
 2. Materials designated for these parts conform to NACE MR0103 Class I or Class II bolting requirements.
 3. Materials and processes in accordance with the requirements of NACE MR0103. Applications requiring compliance to NACE MR0175 - 2003 or ISO 15156 must be reviewed by Masoneilan.

Steam Service Material Options

Ref. No	Temperature Range	-20°F	-450°F	-650°F	-800°F	-950°F	-1100°F
		-29°C	-232°C	-343°C	-426°C	-510°C	-593°C
Description		Standard and Optional Materials					
1	Body	Carbon Steel					
		Chromoly Steel					
2	Bonnet	Carbon Steel					
		Chromoly Steel					
3	Bonnet Flange	Carbon Steel					
		Chromoly Steel					
4	Body Stud	Alloy Steel ASTM A193 Gr B7			316 St. St. ASTM A193 Gr B16	Super Alloy ASTM A453 Grade 660	
5	Body Nut	Alloy Steel ASTM A194 Gr 2H			Carbon Steel Alloy Steel ASTM A194 Gr 4	304 St. St. ASTM A194 Gr 8	
6	Metal Seal	Alloy Steel					
7	Stem	17-4 PH Condition H-1150M			Inconel® X-750		
8	Plug	316 Stainless Steel / Chrome Plated and Hardfaced			420 Stainless Steel		
					4130 Alloy Steel		
9	Seal Ring Sub-Assembly	PTFE + 25% Graphite and ELGILOY® Spring			Graphite		
					Nitrided CAGNM		
10	Cage	316 Stainless Steel			410 Stainless Steel		
					Inconel® 718		
11	Cage Retainer	316 Stainless Steel			410 Stainless Steel		
13	Seat Ring	316 Stainless Steel with Hardfaced Seat			416 Stainless Steel		
14	Gasket	316 Stainless Steel with Flexible Graphite Filler (Spiral Wound)			Inconel® with Graphite (Spiral Wound)		
15	Packing Flange Stud	304 Stainless Steel ASTM A193 Gr B8 Class 2					
16	Packing Flange Nut	304 Stainless Steel ASTM A194 Gr 8					
17	Packing Flange	300 Series Stainless Steel					
18	Packing Follower	300 Series Stainless Steel					
19	Packing Sub-Assembly	Teflon® V-Ring			Flexible Graphite		
20	Guide Bushing	RTFE			Stellite® 6 UNS 30006		

- Notes:
1. The materials listed above are for standard configurations.
 2. Specific applications may require material changes for optimum performance.
 3. Consult factory for applications above 800°F or where large thermal transients exist.

Selection Instructions

Specifying an energy management or low noise product involves sound engineering judgment and application understanding. Masoneilan has developed a computer-based valve sizing and selection program to aid our application specialists in choosing the correct product. Each 72000

Series valve is specified with the Best Fit number of turn or stages according to the noise requirements and pressure drop ratio. Please contact your local Masoneilan representative for application assistance.

Typical Dimensions

Approximate Body Dimensions

Approximate dimensions for 72000 Series valve are intended for estimating purposes only. Dimensions for a specific design can be provided by the factory upon request.

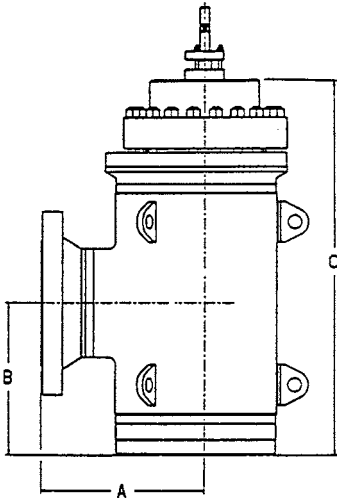

Size (Inch)	Dimension for ANSI 300# (Inch)		
	A	B	C
4 x 6	13	11	24
4 x 8	14	12	25
4 x 10	15	13	26
6 x 6	14	12	28
6 x 8	14	12	29
6 x 10	15	13	31
8 x 8	16	13	33
8 x 10	16	13	34
8 x 12	18	14	35
10 x 10	19	16	36
10 x 16	19	18	38
10 x 18	21	20	39
10 x 20	21	26	42
12 x 12	21	30	42
12 x 16	22	31	44
12 x 18	22	32	45
12 x 20	23	32	46
12 x 24	24	32	50
16 x 16	27	32	50
16 x 20	27	33	52
16 x 24	28	34	56
16 x 30	30	34	60
20 x 20	32	34	64
20 x 24	32	35	68
20 x 30	34	36	68
20 x 36	36	39	70
24 x 24	38	40	70
24 x 30	38	40	70
24 x 36	40	43	71
30 x 30	42	44	72
30 x 36	44	45	75

Size (Inch)	Dimension for ANSI 300# (mm)		
	A	B	C
4 x 6	330	279	610
4 x 8	356	305	635
4 x 10	381	330	660
6 x 6	356	305	711
6 x 8	356	305	737
6 x 10	381	330	787
8 x 8	406	330	838
8 x 10	406	330	864
8 x 12	457	356	889
10 x 10	483	406	914
10 x 16	483	457	965
10 x 18	533	508	991
10 x 20	533	660	1067
12 x 12	533	762	1067
12 x 16	559	787	1118
12 x 18	559	813	1143
12 x 20	584	813	1168
12 x 24	610	813	1270
16 x 16	686	813	1270
16 x 20	686	838	1321
16 x 24	711	864	1422
16 x 30	762	864	1524
20 x 20	813	864	1626
20 x 24	813	889	1727
20 x 30	864	914	1727
20 x 36	914	991	1778
24 x 24	965	1016	1778
24 x 30	965	1016	1778
24 x 36	1016	1092	1803
30 x 30	1067	1118	1892
30 x 36	1118	1143	1905

Approximate Shipping Weights

Approximate shipping weights are intended for estimating purposes. Weights for a specific design can be provided by the factory upon request.

Size (Inch)	Weight for ANSI 300# (lbs)	Size (Inch)	Weight for ANSI 300# (lbs)	Size (Inch)	Weight for ANSI 300# (lbs)
4 x 6	1,000	10 x 18	3,500	20 x 20	11,250
4 x 8	1,100	10 x 20	3,800	20 x 24	12,500
4 x 10	1,250	12 x 12	4,000	20 x 30	14,000
6 x 6	1,100	12 x 16	4,200	20 x 36	15,000
6 x 8	1,200	12 x 18	4,500	24 x 24	13,000
6 x 10	1,400	12 x 20	5,000	24 x 30	14,500
8 x 8	1,600	12 x 24	6,000	24 x 36	15,500
8 x 10	1,700	16 x 16	6,500	30 x 30	15,000
8 x 12	2,000	16 x 20	7,250	30 x 36	16,000
10 x 10	3,000	16 x 24	8,500		
10 x 16	3,200	16 x 30	10,000		

Size (Inch)	Weight for ANSI 300# (kgs)	Size (Inch)	Weight for ANSI 300# (kgs)	Size (Inch)	Weight for ANSI 300# (kgs)
4 x 6	454	10 x 18	1,588	20 x 20	5,103
4 x 8	499	10 x 20	1,724	20 x 24	5,670
4 x 10	567	12 x 12	1,814	20 x 30	6,350
6 x 6	499	12 x 16	1,905	20 x 36	6,804
6 x 8	544	12 x 18	2,041	24 x 24	5,897
6 x 10	635	12 x 20	2,268	24 x 30	6,577
8 x 8	726	12 x 24	2,722	24 x 36	7,031
8 x 10	771	16 x 16	2,948	30 x 30	6,804
8 x 12	907	16 x 20	3,289	30 x 36	7,258
10 x 10	1,361	16 x 24	3,856		
10 x 16	1,452	16 x 30	4,536		

Accessories and Options

For complete information and specifications on the following contact your Masoneilan Representative.

Actuation/Instrumentation

- Higher Thrust Pneumatic Cylinders up to 1,000 square inch effective area
- Electric Actuators
- Hydraulic manual override for pneumatic piston actuators
- Dust boot for plug/actuator stem
- Fast response package for quick opening times
- Smart Systems/On line diagnostics

Valve

- Other body materials
- Special end connections
- Special trim materials
- Custom trim characterization
- Body drain plug
- Extension bonnets

Documentation and Test

- Nondestructive examination
- Response verification
- Certified material test reports
- Flow testing (through 8" outlet only)

Notes

Notes

DIRECT SALES OFFICE LOCATIONS

BELGIUM

Phone: +32-2-344-0970
Fax: +32-2-344-1123

BRAZIL

Phone: +55-11-2146-3600
Fax: +55-11-2146-3610

CANADA

Ontario
Phone: +905-335-3529
Fax: +905-336-7628

CHINA

Phone: +86-10-8486-4515
Fax: +86-10-8486-5305

FRANCE

Courbevoie
Phone: +33-1-4904-9000
Fax: +33-1-4904-9010

GERMANY

Viersen
Phone: +49-2162-8170-0
Fax: +49-2162-8170-280

INDIA

Mumbai
Phone: +91-22-8354790
Fax: +91-22-8354791

New Delhi
Phone: +91-11-2-6164175
Fax: +91-11-5-1659635

ITALY

Phone: +39-081-7892-111
Fax: +39-081-7892-208

JAPAN

Chiba
Phone: +81-43-297-9222
Fax: +81-43-299-1115

KOREA

Phone: +82-2-2274-0748
Fax: +82-2-2274-0794

MALAYSIA

Phone: +60-3-2161-0322
Fax: +60-3-2163-6312

MEXICO

Phone: +52-5-310-9863
Fax: +52-5-310-5584

THE NETHERLANDS

Phone: +31-15-3808666
Fax: +31-18-1641438

RUSSIA

Veliky Novgorod
Phone: +7-8162-55-7898
Fax: +7-8162-55-7921

Moscow
Phone: +7 495-585-1276
Fax: +7 495-585-1279

SAUDI ARABIA

Phone: +966-3-341-0278
Fax: +966-3-341-7624

SINGAPORE

Phone: +65-6861-6100
Fax: +65-6861-7172

SOUTH AFRICA

Phone: +27-11-452-1550
Fax: +27-11-452-6542

SOUTH & CENTRAL AMERICA AND THE CARIBBEAN

Phone: +55-12-2134-1201
Fax: +55-12-2134-1238

SPAIN

Phone: +34-93-652-6430
Fax: +34-93-652-6444

UNITED ARAB EMIRATES

Phone: +971-4-8139-200
Fax: +971-4-8838-038

UNITED KINGDOM

Wooburn Green
Phone: +44-1628-536300
Fax: +44-1628-536319

UNITED STATES

Massachusetts
Phone: +1-508-586-4600
Fax: +1-508-427-8971

Corpus Christi, Texas
Phone: +1-361-881-8182
Fax: +1-361-881-8246

Dresser Direct
Deer Park, Texas
Phone: +1-281-884-1000
Fax: +1-281-884-1010

Dresser Flow Technologies
Houston, Texas
Phone: +1-281-671-1640
Fax: +1-281-671-1735

California
Phone: +1-562-941-7610
Fax: +1-562-941-7810

About Dresser, Inc.

Dresser, Inc. is one of the leading providers of reliable, highly engineered infrastructure products for the global energy industry. Dresser's highly regarded portfolio of brands includes Wayne® payment and fueling systems; Waukesha® natural gas-powered engines and generator sets, Masoneilan® control valves, Consolidated® pressure relief valves, and Roots® blowers and compressors. With locations worldwide, Dresser, Inc. serves customers in more than 100 countries. www.dresser.com

About Dresser Masoneilan

Dresser Masoneilan, headquartered in Houston, Texas, has been the leading global partner in process control valves and solutions for more than 100 years. A business segment of Dresser, Inc., the company delivers customized products, services and diagnostic solutions for oil and gas, process and power generation applications. www.dresser.com

Dresser Masoneilan Dresser, Inc., Flow Technologies

10343 Sam Houston Park Drive
Houston, Texas 77064 U.S.A
T. +1-281-671-1640
F. +1-281-671-1735
E. sales@masoneilan.com

